



inVENTer

Installation instructions

iV-Office



Ventilation device
with heat recovery



Trademarks, copyrights and property rights

inVENTer®, Xenion®, inVENTron®, Inventin and Clust-Air® are registered trademarks of inVENTer GmbH.

The copyright to this document remains with the manufacturer.
Rights to all content and images: © inVENTer GmbH 2022.

All trademarks used in this document are the property of their respective manufacturers and are hereby acknowledged.

Disclaimer

This documentation represents an translation of the original German installation instructions. After completion of the installation the information regarding access to these installation instructions must be handed over to the user (tenant, owner, property management, etc.). The content of this documentation has been checked for compliance with the described components. Nevertheless deviations may still occur, therefore no guarantee of compliance can be provided.

This documentation describes the functionality of the standard scope. For reasons of clarity, the documentation does not purport to cover all details on all types of the product and cannot cover every conceivable scenario for installation and assembly.

The illustrations in this document may differ slightly from the design of the product that you have purchased. The same functionality is ensured despite any design deviations.

This documentation is updated regularly. Necessary corrections and appropriate supplements are always included in subsequent editions. You can also find the latest version at **www.inventer.eu/downloads**.

Company information

Publisher:

inVENTer GmbH
Ortsstraße 4a
D-07751 Löberschütz
Germany

Phone: +49 (0) 36427 211-0
Fax: +49 (0) 36427 211-113
E-mail: info@inventer.de
Web: www.inventer.eu

CEO: Annett Wettig
VAT ID number: DE 815494982
Jena District Court HRB 510380

Table of contents

1	User and safety instructions	4
1.1	User information.....	4
1.2	Safety instructions.....	5
2	System overview: iV-Office ventilation device	8
2.1	Construction.....	9
2.2	Function	10
2.3	Control elements.....	12
3	Preparing for installation	14
3.1	Installation position.....	14
3.2	Position of the wall opening	15
3.3	Dimensions	15
3.4	Sectional drawing of the ventilation device	16
3.5	Dimensional drawings of components	17
4	Installation and assembly	18
4.1	Check the scope of supply.....	18
4.2	Create wall opening	19
4.3	Laying the cables to the wall opening of the ventilation device	20
4.4	Installing the wall sleeve	22
4.5	Installing the ventilation device's external termination	24
4.6	Inserting the thermal accumulator insert.....	26
4.7	Installing the inner cover base plate.....	29
4.8	Electrical connection of the reversible fan.....	31
4.9	Check function and complete fan installation.....	33
4.10	Installing the inner cover panel	34
5	Technical data	35
5.1	General specifications.....	35
5.2	iV-Office energy label according to ErP Directive, Regulation 1254/2014	36
5.3	Specifications according to ErP Directive, Regulation 1254/2014	37
6	Scope of supply	39
7	Troubleshooting	40
8	Warranty and guarantee	41
9	Service	41

1 User and safety instructions

Thank you for purchasing this high quality product from inVENTer!

This section provides an overview of the basic safety precautions for safe and proper operation of your ventilation device.

1.1 User information

Safety and warning instructions

The safety and warning instructions in these installation instructions have a uniform structure and are marked with a symbol on the left side of the instruction. A signal word in front of the text also indicates the hazard level. If several hazard levels exist, the highest level safety instruction is always used.

The safety and warning instructions contain the following information:



SIGNAL WORD: Type and origin of the hazard. Possible consequences of the hazard!
Measures to avoid the hazard.



The signal word indicates the severity of the potential hazard unless the preventive measures are taken:



DANGER means: Imminent danger of serious injury or death.



WARNING means: Possible danger of serious injury or death.

CAUTION means: Direct danger of minor/significant injury.



NOTICE means: Direct or possible risk of property damage due to an adverse event/state.

If you see these signs, ensure you observe the described measures to prevent possible hazards and/or damage.

Other symbols used in this documentation

In addition to the safety instructions, the following symbols are used:



A **TIP** symbol indicates practical and useful tips for handling your ventilation system.



Before each step, any additional **tools and materials required** for the activity are listed.



Red bar over a graphic: graphic shows the interior wall.



Blue bar over a graphic: graphic shows the exterior wall.



Action required: This prompts the user to perform a specific action.



Check the results requires you to check the results of the action you have performed.



Action focus: To be taken into account in the corresponding assembly step.

1.1 Safety instructions

The installation instructions are part of your iV-Office ventilation device and must be available at all times (see www.inventer.eu/downloads). When handing the system to a third party, the information regarding access to the installation instructions must be handed over also.

Before performing any work on the device/system, read the installation instructions carefully and observe all notices that refer to the installation process in this section. Also note the safety instructions that precede the described handling instructions.

Non-observance of safety instructions could result in injury and/or property damage.

These installation instructions only cover the standard variant (referred to as the "Standard variant" in the following text) of the iV-Office ventilation device. Information on the variants can be found in the separate installation instructions for the respective components.

Intended use

The ventilation device is designed to ventilate dwellings and similar residential spaces and other areas where people spend time e.g. living rooms and bedrooms, offices, basements and attics. It is controlled via an inVENTer system control device (hereinafter referred to as the "controller").

General information

- Always observe the relevant standards, regulations and guidelines when installing the equipment / system. In particular also applicable building regulations, fire safety regulations and accident prevention regulations of the employers' liability insurance association.
- Use the device/system exclusively for the applications that are described in this documentation and only in conjunction with components that are recommended, authorised and described by inVENTer GmbH in this documentation.
Changes or modifications to the equipment/system are not permitted.
- Your ventilation system is exclusively designed for use in ambient temperatures between -20 and 50°C.
- Trouble-free and safe operation of the equipment / system depends on proper transportation, proper storage and installation, as well as careful operation and cleaning / care.
- The ventilation device is based on the free movement of air between individual pairs of ventilation devices. Therefore, internal doors must not have air-tight seals. Provide suitable air transfer measures to create a room network (cross ventilation).

Installation and assembly



- **CAUTION: The system may only be installed by qualified personnel.**
- Before starting work, you should have a project plan showing the number of ventilation devices, the location of the ventilation devices, the ventilation principle (cross ventilation, single room ventilation, extract ventilation) and the associated controllers. The exact positioning of the individual devices and control devices must be checked at the installation site and, if necessary, adapted to the local conditions with the involvement of the responsible planner or user. For optimum functionality, it is recommended to install the device at an appropriate place in the upper wall area.





- **WARNING:** For joint operation with fireplaces, safety measures must be taken to prevent a negative pressure from developing in the building. The responsible chimney sweep and/or building planner decides which measures need to be carried out.

- 

• **NOTICE:** The ventilation device is not suitable for drying out buildings. Do not put it into operation until the construction work has been completed.
- **NOTICE:** Contamination of components, e.g. by plaster residue, will damage the components! Seal the ventilation device/air outlets of the ventilation device so they are dust-tight throughout the construction work. Do not remove the thread locks until final assembly.
- **NOTICE:** Do not install the device near indoor air thermostats or in the immediate vicinity of/ above sensitive pictures or furniture.
- **NOTICE:** Observe the specified minimum clearances on both sides of the wall and frontally to prevent unintentional mixing of different air flows and to ensure access to the device and its components. A minimum distance of 1.2 m must be maintained between adjacent air openings. (📐, page 14 f.).
- **NOTICE:** The wall sleeve must be integrated into the building envelope (airtightness level) in accordance with the current state of the art, taking into account construction-related and physical specifications ("RAL installation"). Material for this is must be provided on site.
- **NOTICE:** When bringing the wall construction up to the wall sleeve, observe the necessary blocking levels to avoid interrupting the composite thermal insulation system. Consult your planner before installation if you are at all uncertain!
- **NOTICE:** Install the wall sleeve with a slope of 1 - 2° to the exterior wall to ensure the drainage of any condensate that may form.
- **NOTICE:** Do not install the ventilation device in places where direct contact with water spray is possible. Observe the specifications of VDE 0100 when choosing the installation location.
- **NOTICE:** Store components standing outside the wall sleeve and do not throw them to avoid damage and breakage of the components, especially the thermal accumulator.
- **NOTICE:** In order to avoid algae growth around the external terminations, the instructions for installation must be followed exactly (apply all sealing tapes!). We recommend a biocidal pre-treatment/water-repellent pre-treatment of the façade surface around the external terminations. Consult your planner about this!
- **NOTICE:** When installing components in (exterior) walls with insulation, use insulation wallplugs to ensure that the components are securely fastened.
Insulation wallplugs are not included in the scope of supply, they are available as an option!
- **NOTICE:** Only use permanently elastic sealing compound suitable for outdoor use to seal the joints at all external edges!
- **NOTICE:** The device has scratch-sensitive plastic surfaces. Do not touch the components with oily and/or dirty hands. Avoid contact with sharp or pointed objects, e.g. rings.

Cabling / connection of the reversible fan

- 

• **CAUTION:** The system's electrical connections may only be carried out by qualified electricians.
- 

• **NOTICE:** The reversible fan operates with protective extra-low voltage. It must not be connected directly to the 230 V power grid.
- **NOTICE:** Laying cables whose sheathing is not resistant to plastering under plaster leads to short circuits and cable fire! Lay cables without a plaster-resistant cable sheath in the conduit.
- **NOTICE:** The use of too small a cable cross-section leads to too great a voltage drop and/or contact is not guaranteed! For the fan BUS, use a cable cross-section of at least 0.75 mm² (stranded wire). Use wire ferrules with collars to connect the strands.
- When using several ventilation devices controlled by several controllers, you must ensure that the ventilation devices are synchronised with each other (see installation instructions for controllers). You should connect all controllers via a mains fuse in the house distribution board.

If your device has a fault, contact your nearest distributor or our technical service.
Any kind of use other than the intended use will exclude all liability claims.

Improper use

Any use that is not mentioned in the intended use section, is considered to be improper.

Especially do not install / operate the device in areas which the following may occur:

- Environment containing strong oils or lubricants.
- Flammable, aggressive and corrosive gases, liquids or vapours.
- Extreme dust exposure.
- Ambient temperatures outside the range of -20 to 50 °C.

The ventilation device is not to be used as an opening to the outside and/or for the purpose of smoke removal/smoke extraction in basements without windows. Prevent obstacles that hinder access to, or removal of, components of the ventilation device.

Qualified personnel

The equipment/system may only be set up, operated and cleaned in conjunction with this documentation and the documentation for the controllers.

Installation, electrical connection and commissioning of the equipment/system may only be performed by qualified personnel. Qualified personnel within the meaning of the safety notices in this documentation are persons who are authorised to install, put it into operation and identify equipment, systems and circuits in accordance with established safety procedures.

Conformity

The ventilation device complies with the technical safety requirements and standards of electrical appliances for domestic use. It conforms to current European Union and United Kingdom directives. The full text of the EU declaration of conformity is available at the following Internet address: <https://www.inventer.eu/downloads/> .

2 System overview: iV-Office ventilation device

The iV-Office is a decentralised ventilation system with heat recovery and is designed for increased air flow requirements (performance-plus device). The iV-Office is suitable for installation in new buildings as well as for retrofitting in older buildings and is particularly suitable for use in large living spaces and similar commercial premises (e. g. offices, doctors' surgeries, lounges, etc.). Installation is generally carried out in the exterior wall.

The ventilation device consists of a wall sleeve in which the thermal accumulator insert is mounted. A lockable inner cover conceals the iV-Office discreetly from the interior. The filter integrated into the inner cover ensures that no pollen or dust from outside enters the interior. Outside, a driving rain-proof cover conceals the components of the ventilation device.

The sound insulation lining made of Inventin, a material specially developed to reduce noise, is inserted into the wall sleeve. The insulated wall sleeve incorporates the ceramic thermal accumulator and inVENTron, two guiding vane elements and the Xenion EFP reversible fan. The guiding vanes on both sides of the fan serve to straighten the air flow and ensure more efficient flow through the thermal accumulator. The sound-absorbing Inventin lining and the unique geometry of the Xenion EFP reversible fan effectively reduce the passage of sound.

The standard length of the wall sleeve is 495 mm. For thicker walls, a wall sleeve and insert with a length of 745 mm can be ordered as an alternative. Both versions can be shortened on site.

The ventilation device is controlled via one of the following inVENTer system controllers¹⁾:

- Pure
- sMove
- MZ-Home

Components

- Inner cover incl. ISO Coarse 60 % filter
- Thermal accumulator insert (thermal accumulator, inVENTron and sound insulation lining made of Inventin)
- Wall sleeve
- External termination²⁾
- Pollen and activated carbon filter (optional)
- Sound and wind protection accessories (optional)

Models

The ventilation devices of the iV-Office product range differ in their external terminations. Additional inner covers are also available. This documentation only contains information on the standard version of the ventilation device.

For information on the variants of the exterior and internal terminations, please refer to the separate installation instructions for the respective component:

- **Standard variant:** iV-Office ventilation device with Flex Office driving rain-proof weather protection hood (white/grey/anthracite/custom colour).

¹⁾ The installation and operating instructions for the controller are not part of this documentation.

²⁾ All external terminations are available in stainless steel or optionally in aluminium [increased salt resistance].

2.2 Function

Decentralised ventilation

Decentralised ventilation systems combine extract and supply air and are based on free air movement between individual pairs of ventilation devices (cross-ventilation). The cross-ventilation principle allows the air to circulate through the entire residential device and also sufficiently ventilate interior living spaces. Each ventilation device is mounted in its own air duct so as not to obstruct other ventilation processes.

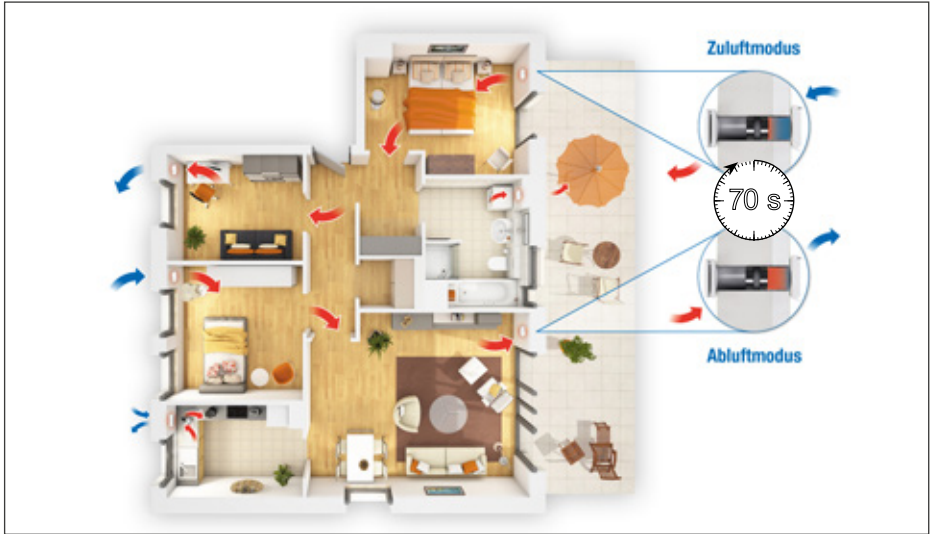

The decentralised iV ventilation systems with heat recovery consist of ventilation devices arranged in pairs with simple air flow. They operate according to the principle of heat recovery by changing the direction of the fan. The integrated thermal accumulator is charged with the thermal energy of the room air as it flows externally (extract air). After 70 seconds, the reversing fan changes the direction of rotation each time. After the direction of rotation has changed, the heat accumulator releases the stored heat energy to the incoming fresh air (supply air).

For this principle to work correctly and to ensure pressure stability in the room, the supply air volume must always correspond to the extract air volume, i.e. at least two ventilation devices are required. These are operated in pairs in push-pull mode: another ventilation device is assigned to the ventilation device that delivers supply air and at the same time removes extract air from the interior to the outside.

You operate the iV ventilation systems intuitively with the matching inVENTer controllers. Different operating modes or the air volume flows can be set individually.

The most important components of the iV system are the ceramic thermal accumulator, the reversing fan, air guiding vanes for straightening the air volume flow, filters for different hygienic requirements, a closable inner cover and an outer cover. A control device (controller) completes the system.

Ventilation device iV-Office with heat recovery

The iV-Office ventilation system is used to provide ventilation for living spaces and living space-like commercial premises. The combination of inVENTron, thermal accumulator and sound insulation lining ensures maximum heat recovery with minimum sound emissions and maximum air flow.

It is a ventilation device with simple airflow and works according to the principle of heat recovery by changing the direction of the fan.

The iV-Office features especially quiet operation. The patented sound insulation concept is based on the combination of the sound insulation lining made of Inventin with the Xenion EFP reversible fan. The sound insulation lining effectively absorbs sound waves from outside and from the device itself (sound transmission and inherent sound). The arrangement and design of the fan blades additionally reduces the sound transmission from outside.

Thanks to a high pressure build-up and the active speed control of the motor (integrated wind pressure stabiliser) in the Xenion EFP reversible fan, the air flow in the system is kept almost constant even in the event of weather-related pressure fluctuations. Thus, the sensitivity of the air flow to pressure fluctuations corresponds to class S2 according to EN 13141-8 (max. 20 % air flow deviation at ± 20 Pa).

In order to ensure the full functioning of the ventilation device throughout the entire year, a temperature sensor is integrated into the Xenion EFP reversible fan. This measures the temperature of the air flow. If the temperature falls below $+5$ °C, the reversible fan is automatically switched to extract air mode for 4 cycles. This allows the thermal accumulator to heat up again and prevents cooling of the interior due to cold supply air. During this phase, the operating mode that has been set on the controller is ineffective. Subsequently, the controller switches the ventilation device back to the originally selected mode.

As standard, a washable ISO Coarse 60 % class dust filter is integrated into the inner cover. This filters coarse dust and allergenic particles (such as coarse flower pollen) from the air before they can enter the interior. The dust filters can be used regardless of the season. Optional pollen and activated carbon filters are available for special requirements.

2.3 Control elements

The ventilation device is operated via an inVENTer system controller. Depending on the controller, different operating modes and functions can be set.

Basic controls

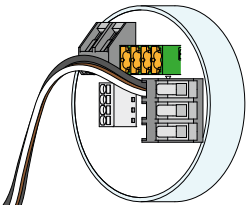
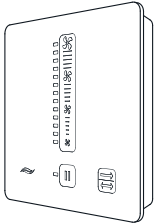
Designation	Pure	sMove
		
Number of controllable ventilation devices	Max. 2	s4: Max. 2 s8: Max. 4
Multi-zone control	No	No
Operating concept	<ul style="list-style-type: none"> • Switch 	<ul style="list-style-type: none"> • Touch
Operating modes	<ul style="list-style-type: none"> • Heat recovery • Unidirectional ventilation • OFF (standard version only) 	<ul style="list-style-type: none"> • Heat recovery • Unidirectional ventilation • OFF (standard version only)
Functions	<ul style="list-style-type: none"> • Pause-Function (1 h) 	<ul style="list-style-type: none"> • Pause-Function (1 ... 8 h) • Boost-Function (1 h)
Fan speed	3 Output levels, predefined	infinitely adjustable, 4 Output levels, predefined
Device communication	Cable	Cable
External interface	1 potential-free switching contact per Control module: <ul style="list-style-type: none"> • Pressure switch (NC) • Other sensors (NO) 	1 potential-free switching contact per controller: <ul style="list-style-type: none"> • Pressure switch (NC) • Other sensors (NO)

Multi-zone control

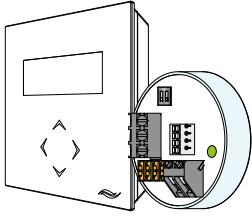
Designation	MZ-Home
	 <p><i>Operating Unit & Clust-Air module</i></p>
Number of controllable ventilation devices	Max. 8 (excl. sensors)
Multi-zone control	max. 4 zones with max. 2 devices [plus sensors] per zone
Operating concept	<ul style="list-style-type: none"> • Touch • Weekly timer
Operating modes	<ul style="list-style-type: none"> • Heat recovery • Through-ventilation • OFF
Functions	<ul style="list-style-type: none"> • Pause function (1... 8h) per zone • Dehumidification with variable air volume flow
Fan speed	4 Output levels, freely selectable
Device communication	Cable
External interface	1 potential-free switching contact per Clust-Air module (max. 4) <ul style="list-style-type: none"> • Pressure switch (NC/NO) • Other sensors (NO)

For detailed information, see the controller's installation and operating instructions.

3 Preparing for installation

3.1 Installation position

- The installation location can be derived from the position suggested by the ventilation planning. The exact positioning of the individual devices and control devices must be checked on site and, if necessary, adjusted. **Consult the responsible planner about this!** For optimum function, it is recommended that the ventilation device is installed at the appropriate point in the upper wall area (e.g. 1.80 m from the upper edge of the finished floor [UEFF]).
- Do not place the ventilation device near radiators, indoor air thermostats, sensitive furniture or above pictures.
- Do not install the device in places where direct contact with water spray is possible. Observe the specifications of VDE 0100 when choosing the installation location.

Minimum distances of the wall opening for the ventilation device:

- Minimum distances to components / building elements on the interior and exterior wall:



NOTICE: Malfunction due to incorrect positioning of the ventilation device.

- Note insulation thickness and possibly shutters!
- Do not install near radiators!
- Observe minimum distance of 1.2 m to adjacent air openings!

Termination component	Distance from centre of hole on the		
	exterior wall [mm]	Internal wall [mm]	frontal [mm]
Flex Office weather protection hood	450 (top) 250 (side, bottom)	–	–
Flair XL inner cover	–	250 circumferential	300

- between two ventilation devices (pair of devices) operating in push-pull mode in a room

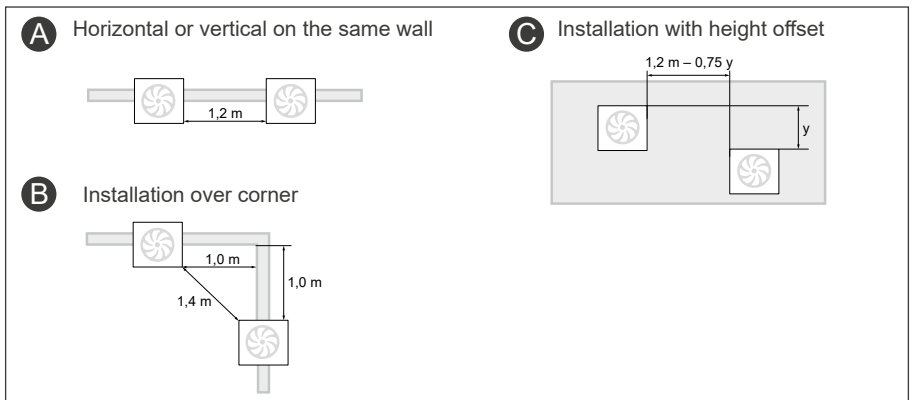

3.2 Position of the wall opening

For the positioning of the wall sleeve of other variants of your ventilation device, see the installation instructions for your specific external termination.

Standard variant ventilation device:

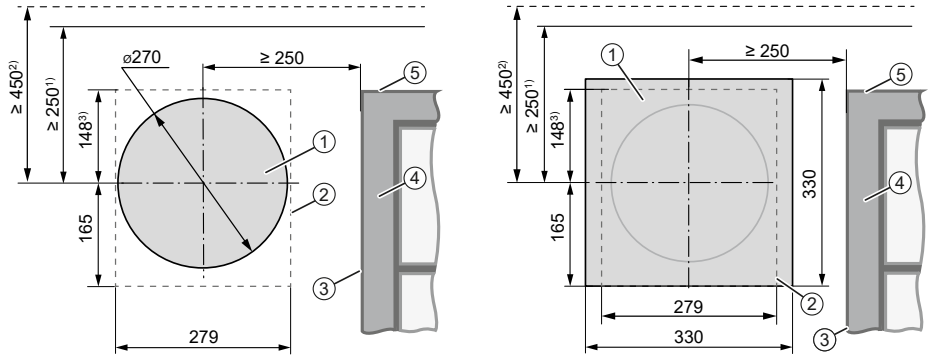

Position of wall opening

Position of Simplex wall sleeve system

Figure 2: Dimensional drawing of the iV-Office wall opening (interior view)

- 1 Wall opening (Fig. 2, left)
- 2 Contour of weather protection hood²⁾
- 3 Reveal
- 4 Door/window frame
- 5 Bottom edge of lintel⁴⁾

¹⁾ Minimum distance to adjacent components on the interior wall ³⁾ Recommendation: Attach the hood at lintel height
²⁾ Ensure a minimum distance to adjoining components on the exterior wall ⁴⁾ Note insulation thickness and any roller shutters

3.3 Dimensions

Designation	Depth/length [mm]	Width [mm]	Height [mm]
Wall opening for wall sleeve	Wall thickness ¹⁾	Ø270	
R-D250 wall sleeve	495 (745)	Ø250	
Flex Office weather protection hood	23 – 88	279	313
Flair-XL V-280x280 inner cover	63 ²⁾	280	280

¹⁾ with render, insulation, masonry and plaster ²⁾ Open

3.4 Sectional drawing of the ventilation device

For sectional drawings of other variants of your ventilation device, see the installation instructions for your specific external termination.

Sectional drawing of the iV-Office ventilation device, standard variant

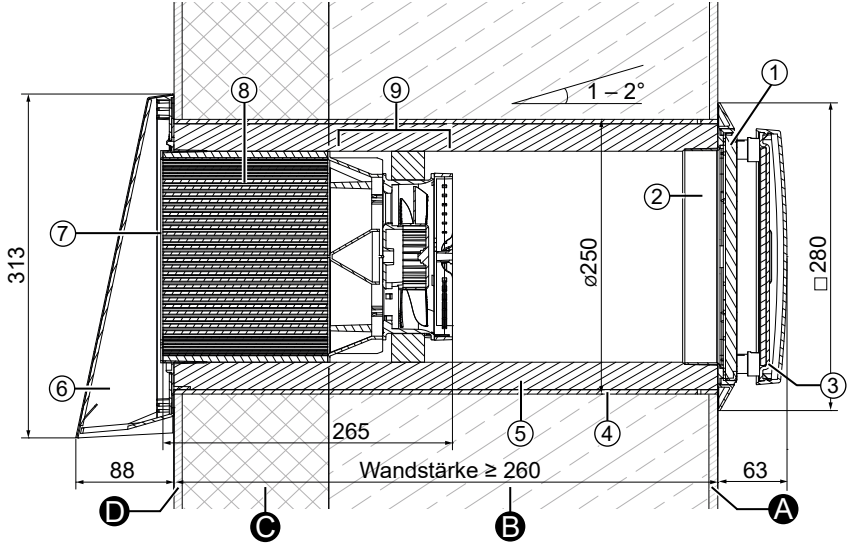

Figure 3: Sectional drawing of the iV-Office ventilation device

A Interior plaster/ interior structure
 B Masonry

C Insulation
 D Render

- | | |
|---|--|
| <p>1 Inner cover base plate</p> <p>2 Flair XL adapter</p> <p>3 Inner cover panel with SDE sound insulation insert</p> <p>4 R-D250 wall sleeve</p> <p>5 Sound insulation lining made of Inventin</p> | <p>6 Flex Office weather protection hood</p> <p>7 Flex Office ring insert (pre-installed)</p> <p>8 Thermal accumulator</p> <p>9 inVENTron R-D200:
 Xenion EFP reversible fan embedded in double guiding vane</p> |
|---|--|

3.5 Dimensional drawings of components

Flex Office weather protection hood

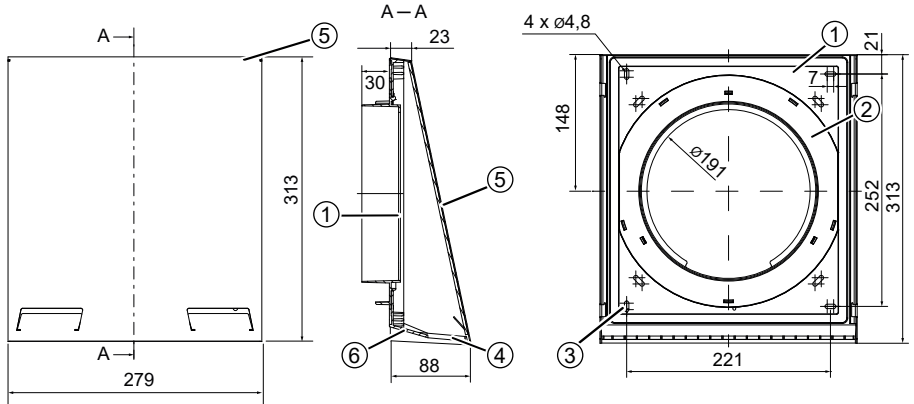

Weather protection hood cover

Weather protection hood base plate

Figure 4: Dimensional drawing of the Flex Office weather protection hood

- | | |
|--------------------------------------|---------------------------------|
| 1 Weather protection hood base plate | 4 Protective grid |
| 2 Flex Office insert (pre-assembled) | 5 Weather protection hood cover |
| 3 Exterior wall fixing hole | 6 Drip rail |

Flair XL inner cover

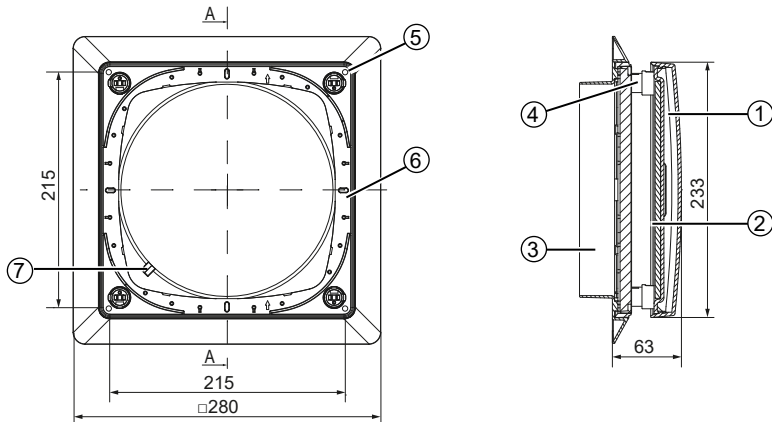

Figure 5: Dimensional drawing of the Flair XL V-280x280 inner cover incl. SDE

- | | |
|-------------------------------|--|
| 1 Inner cover panel | 5 Interior wall fixing borehole |
| 2 SDE sound insulation insert | 6 Inner cover base plate |
| 3 Flair XL adapter | 7 Pass-through for controller connecting cable |
| 4 Spacer (4 x) | |

4 Installation and assembly



Read the section carefully before installation to avoid installation errors. The installation and connection of the ventilation system must be carried out by qualified personnel.

4.1 Check the scope of supply

Check the delivery for completeness and transport damage upon receipt using the delivery note. Report missing items immediately.

These assembly instructions describe the standard version of the product. Details of the variants' scope of supply can be found in the separately available installation instructions for the respective system component.

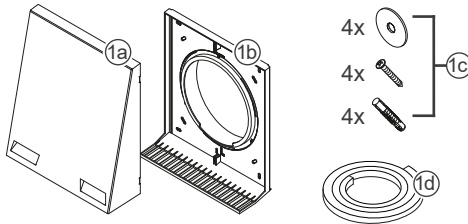

1 External termination

- 1 a: Flex Office WSH cover
- 1 b: Flex Office WSH base plate
- 1 c: Exterior wall fixing elements
- 1 d: Sealing tape

The Flex-Office weather protection cover is available in different colours and materials (stainless steel / aluminium [with increased salt resistance]) and must be ordered according to the desired colour and texture.

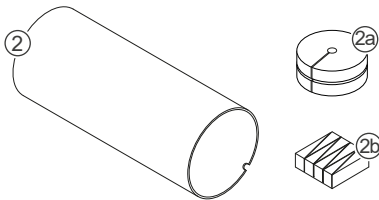

2 R-D250 wall sleeve

- 2 a: Styrofoam discs
- 2 b: Mounting wedges set

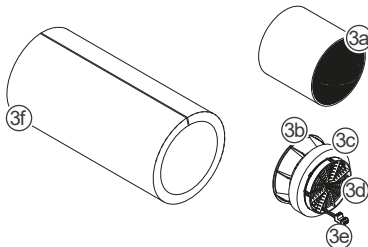

3 Einschub Wärmespeicher iv-Office

- 3 a: Insulated thermal accumulator
- 3 b: R-D200 guiding vane
- 3 c: Xenion EFP reversible fan
- 3 d: Slim guiding vane (16 mm)
- 3 e: BUS plug connection
- 3 f: Sound insulation lining

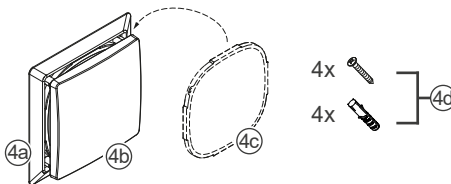

4 Innenblende Flair XL

- 4 a: Flair XL insert (pre-installed)
- 4 b: Inner cover base plate
- 4 c: ISO Coarse 60 % filter
- 4 d: Interior wall fixing material

WSH = Weather protection hood

4.2 Create wall opening



CAUTION

Falling masonry when creating the wall opening

can lead to physical injuries and /or damage to property!

- Install protection against falling masonry on building exterior.
- Remove objects from the immediate vicinity of the building's exterior.

In new buildings, we recommend using the optional Simplex D250 wall installation system.

Observe the minimum distances and the installation position of the ventilation device.
Consult your planner before installation if you are at all uncertain!

Create the wall opening through core drilling



Power drill with core drilling attachment or milling drill \varnothing 270 mm

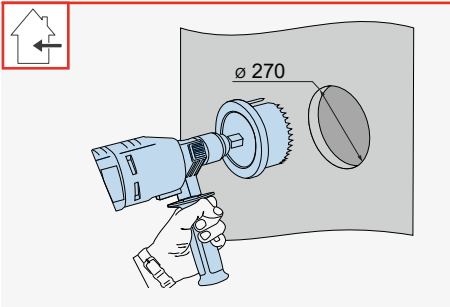

Requirements:

- The masonry must be dry and in a load-bearing condition.
 - No load-bearing elements in the position of the drill hole.
- ▶ Drill a wall opening, \varnothing 270 mm with a slope of 1° to 2° to the exterior wall.
- 👁️! The wall sleeve must have a slope of $1 - 2^\circ$ to the exterior wall side. Alternatively the drilling can be carried through with a slope.

⇒ The wall opening for the ventilation device has been created.

4.3 Laying the cables to the wall opening of the ventilation device



CAUTION

Exposed electrical components.

Injury caused by live components (16 V DC)!

- **Installation and connection must only be performed by qualified and trained personnel.**

Once the wall opening has been created, the cables necessary for operating the ventilation system are laid to the wall opening for the ventilation device. They connect the valve gate of the ventilation device with the control components and thus establish signal transmission and/or voltage transmission between the controller and the Xenion EFP reversible fan.



NOTICE: Cable to the wall opening of the ventilation device not laid. No connection of the reversible fan possible!

Routing of the cables to the wall opening for the ventilation device must be done in this installation step. The routing of the connecting cables between the controllers and the Xenion EFP reversible fan is not part of this documentation. For more information, see the installation and operating instructions for the corresponding controller.

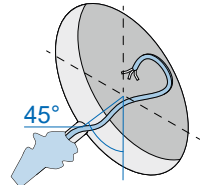

Cable to the wall opening of the ventilation device

The following cables, depending on the control device, are laid to the wall opening for the ventilation device:

	Use	Cable type	Cable origin
Pure	Operating voltage fan and device communication	Stranded cable 6 – 16 V DC, e. g.: LiYY 3x0.75 mm ²	Pure controller module
sMove			sMove operating device
MZ-Home			Clust-Air module CAM17 in the ventilation zone

Principle sketches for cable laying

The corresponding connection diagrams and assembly steps for installing the controller are not part of this documentation! They can be found in the installation and operating instructions for the respective control device.

Pure, sMove and MZ-Home controllers



6 – 16 V DC

~~230 V AC~~

One after the other:

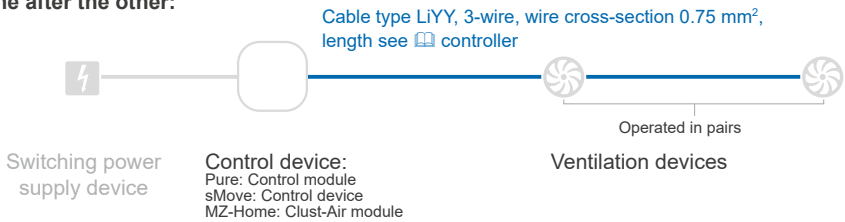

Star-shaped:

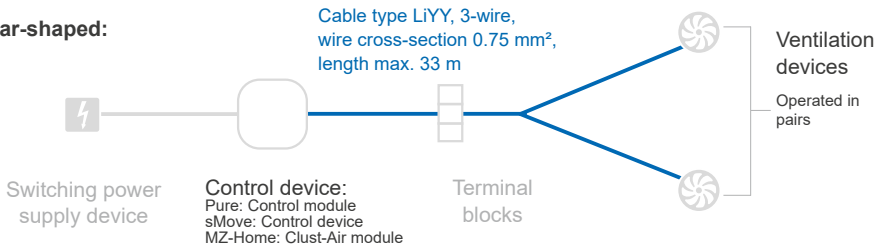

4.4 Installing the wall sleeve



Measuring tape, angle grinder, spirit level, non-pressing 2K polyurethane foam, cutter, mounting wedge set and styrofoam discs

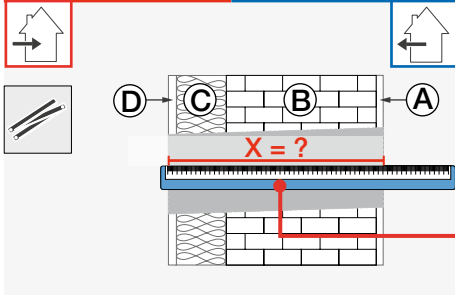

Requirements:

- The wall opening \varnothing 270 mm is finished.
 - The cables to the wall opening of the ventilation device has been laid.
- Determine the exact wall thickness X:
 D = Exterior rendering, incl. other superstructures if applicable.
 C = Insulation, if applicable incl. air gap
 B = Masonry, incl. relining if applicable
 A = Interior plaster

$$X = A+B+C+D$$

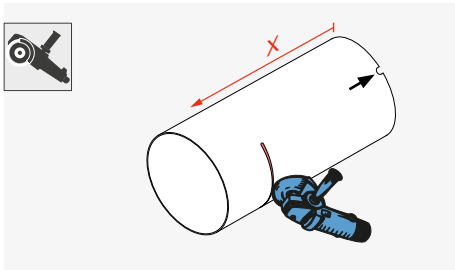

- Cut the wall sleeve to the **determined dimension X**.
 👁️ **Be careful not** to cut away the cut-out for the fan connecting cable.

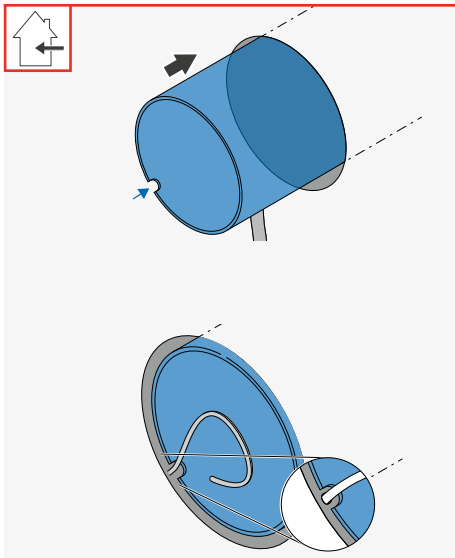

- Remove the styrofoam discs from the wall sleeve.
- Insert the wall sleeve into the wall opening so it is flush with the interior wall.
 Note the thickness of the plaster.
- 👁️ **The recess** for the connecting cables is located on the interior wall side and near the cables laid to the wall opening.
- Guide all connecting cables through the cut-out in the wall sleeve.

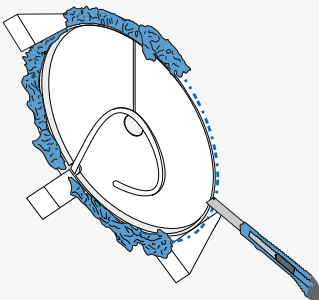
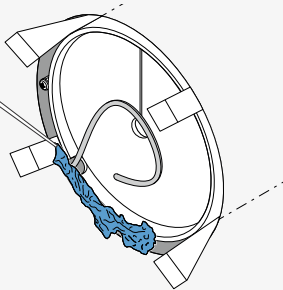
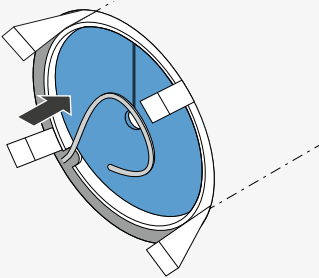
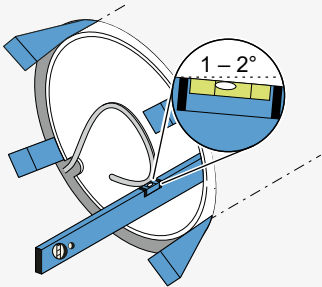

NOTICE: Accumulation of condensation water in the wall sleeve.

Damage to exterior wall and masonry and the building structure!

- Attach the wall sleeve with a slope of 1° to 2° to the exterior wall.

- ▶ Attach the wall sleeve inside and outside with the mounting wedges so that there is a slope of 1 – 2° to the exterior wall.
- ▶ Check the angle of the wall sleeve using a spirit level.



NOTICE: Contamination of the wall sleeve, e. g. by plaster residues, leads to damage to the sound insulation lining made of Inventin!

- Before foaming the free space between the wall sleeve and masonry, insert styrofoam discs.

- ▶ Insert the styrofoam discs into the wall sleeve from the inside and outside.



NOTICE: Interruption of the thermal insulation composite system.

Damage to the building structure!

- During installation, replace the wall structure as far as the wall sleeve.
- Observe the necessary barrier levels.

- ▶ Foam-seal the gap between the wall sleeve and masonry all the way around with non-pressing 2K polyurethane foam.
- ▶ Cut off the excess, hardened 2K polyurethane foam and protruding mounting wedges so they are flush with the exterior and interior wall.
- ▶  Take care **not** to damage the connecting cable on the interior wall.
- ▶ If necessary, trim the wall sleeve so it is flush with the render.
- ▶ Deburr the edges.

⇒ The wall sleeve is installed.

4.5 Installing the ventilation device's external termination

The installation of the external termination variants is not part of this documentation!
It can be found in the installation instructions for the respective external termination.



NOTICE

Installing on an unfinished exterior wall leads to damage to the exterior wall!

- Only install the external termination once the exterior wall is finished and has fully dried.



NOTICE

Penetration of condensation water and/or algae accumulation around the external termination leads to damage to the masonry/exterior wall and/or discolouration of the façade!

- Secure sealing tape all the way around the weather protection hood before installing the external termination.
- Before installation, carry out a biocidal pre-treatment/water-repellent pre-treatment of the surface around the weather protection hood (consult your planner regarding this!).

Installing the Flex Office weather protection hood



Spirit level, pen, power drill with Ø 8mm drill bit, cordless screwdriver, rawl plugs (wallplugs for insulation for insulated exterior walls), permanently elastic external sealant, sealing tape, screws

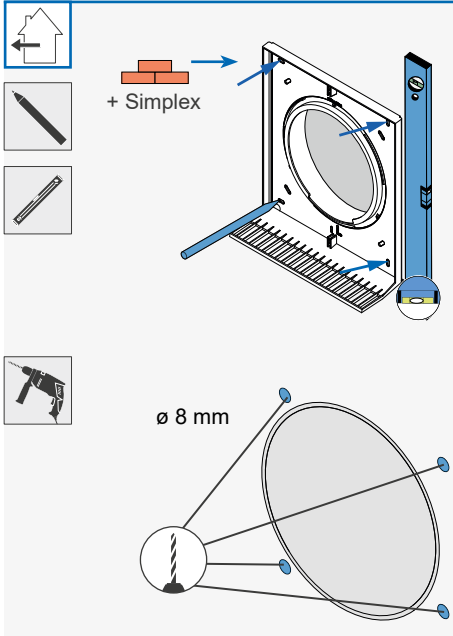

Requirements:

- The exterior wall is completed and even.
 - The wall sleeve is installed.
- ▶ Remove the styrofoam disc from the wall sleeve on the exterior wall side.
 - ▶ Slide the base plate with the pre-assembled insert onto the projecting wall sleeve.
 - 👁️! The protective grid is directed towards the floor.
 - ▶ Level the base plate using a spirit level.
 - ▶ Mark the four drill holes (blue arrow).
 - ▶ Drill the four holes with Ø 8 mm, min. 50 mm deep.

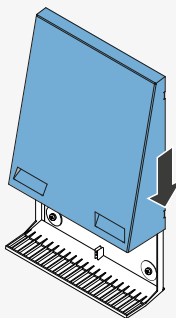
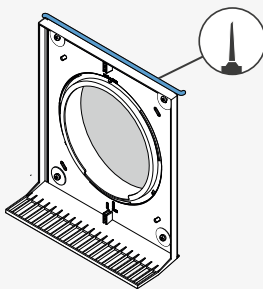
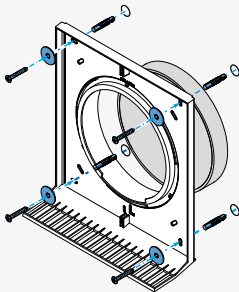
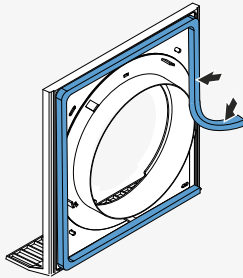

TIP: Do not apply the sealing tape until immediately before installing the base plate. This prevents the sealing tape from swelling too much and makes installation easier.

- ▶ From the exterior wall side, attach the 9-mm sealing tape circumferentially flush with the guide on the base plate.
- 👁️! Do not seal the fixing holes!

- ▶ Insert the rawl plugs into the boreholes.
- ▶ Screw the base plate into the rawl plugs using 4 screws and washers.



TIP: When attaching the base plate to exterior walls with insulation or when using the Simplex wall installation system, use wallplugs for insulation for fixing purposes. These are not included in the scope of supply, they are available as an option.



NOTICE: If the joint between the base plate and the exterior wall is incorrectly sealed, the cover cannot be fitted.

- Seal only the upper joint between the base plate and the exterior wall.

- ▶ Seal the upper joint between the base plate and the exterior wall with a permanently elastic exterior sealant.
- ▶ Place the cover onto the base plate from the top.
- ▶ Slide the cover downwards as far as the stop.
- 👁️! The guides on the cover hook in behind the base plate.

⇒ The Flex Office weather protection hood is installed.

4.6 Inserting the thermal accumulator insert

Inserting the sound insulation lining

- NOTICE:** The sound insulation lining is made from Inventin, a high-performing, patented material for use in decentralised ventilation devices. It absorbs sound waves from outside and from the device itself (sound transmission and inherent sound). Inventin is a sensitive material.
- To safeguard its sound-insulating function, handle the lining with care.



Cutter

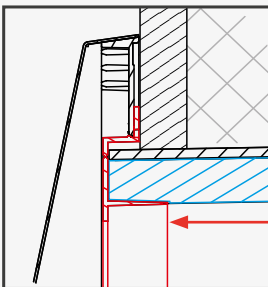
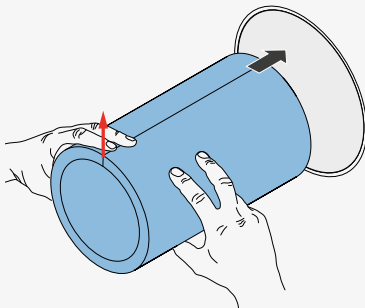
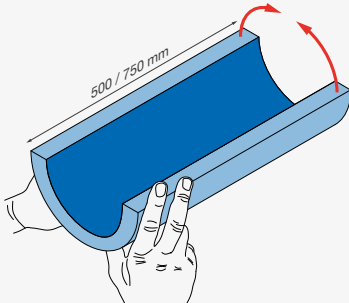

Requirements:

- The external termination is fitted.
- ▶ Remove the styrofoam disc from the wall sleeve.
- ▶ Position the front surfaces of the sound insulation lining together.
- ▶ Push the sound insulation lining with light tension into the wall sleeve until it stops.
- 👁️ **!** Position the abutting surfaces (red arrow) in the upper section of the wall sleeve (approx. 12 o'clock).
- ▶ Make sure that the sound insulation lining made of Inventin is pushed into the ring insert on the weather protection hood.

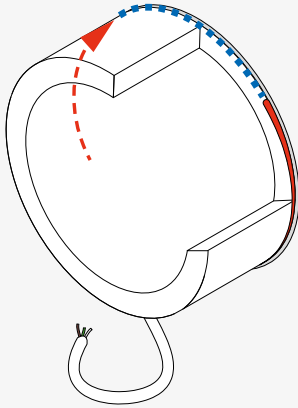

- ▶ Shorten the sound insulation lining on the inner wall side with a cutter so it is flush with the wall sleeve.

 **Do not** damage the connecting cable on the interior wall.

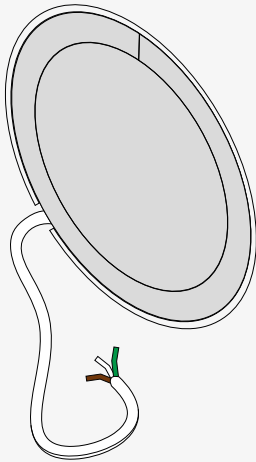

⇒ The sound insulation lining is inserted.

Inserting the thermal accumulator



NOTICE

Do not store/stack the thermal accumulator insert outside the wall sleeve as doing so will damage the thermal accumulator's ceramic.

- Insert the thermal accumulator immediately after removing it from the packaging.

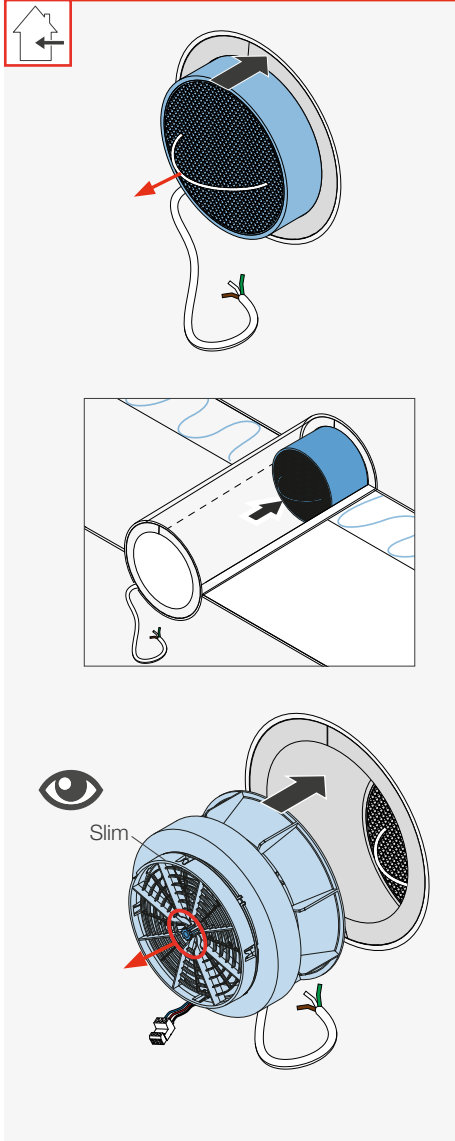

Requirements:

- The external termination is fitted.
 - The sound insulation lining is inserted.
- ▶ Insert the thermal accumulator from the interior into the lined wall sleeve.
- The handle points towards the interior.
 - The connecting cables protrude into the interior.
- ▶ Carefully push the thermal accumulator towards the external termination until it stops.
- Do not damage the sound insulation lining made from Inventin.
- ▶ Insert the inVENTron from the interior into the wall sleeve so that you can reach the BUS plug connection.
- **The narrow Slim guiding vane [16 mm] is aligned towards the interior.**

⇒ The thermal accumulator insert has been inserted.

4.7 Installing the inner cover base plate

The assembly of any interior termination variants is not part of this documentation!
It can be found in the separate installation instructions for the respective component.

Preparing for installation:



The correct installation of the inner cover requires that the installation position of the base plate (installation position arrow pointing upwards) is not changed.

To ensure that, even in the event of a different cable routing, correct connection of the reversible fan is possible, the orientation of the adapter can be modified (e. g. top right cable connection). The adapter for the Flair XL inner cover is pre-assembled at the factory so that the cable entry is located at the bottom left when it is being attached.

If the cable is long enough, it can optionally be laid between the ring insert and the sound insulation lining to the cable entry.

Before installation, check whether any adjustment of the inner cover adapter needs to be made. If necessary, change the position of the cable entry so that it matches the conditions of the installation location:

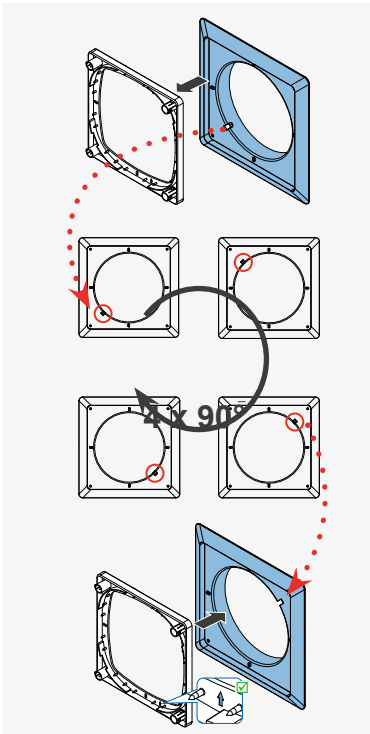

- ▶ Remove the base plate from the adapter by unhooking it on all 4 sides.



TIP: Once the base plate has been removed from the adapter, you can make the drill hole markings for attaching the inner cover to the interior wall.

- ▶ Rotate the adapter by 90° in each case until the positions of the cable entry and connecting cable match.

Bottom left cable entry = position ex works

- ▶ Clip the adapter into the base plate so that
 - The position arrow on the base plate is pointing upwards, and
 - The positions of the cable entry and connecting cable match.

⇒ The inner cover base plate is prepared.



Spirit level, pencil, power drill, cordless screwdriver / Phillips screwdriver, rawl plugs, screws

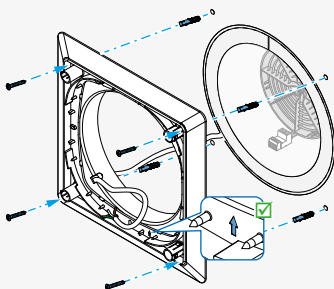
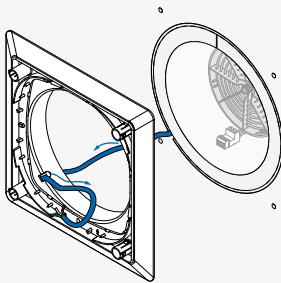
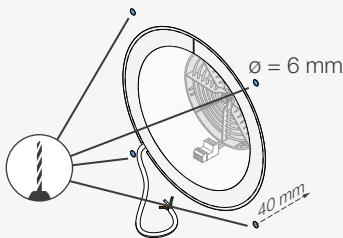
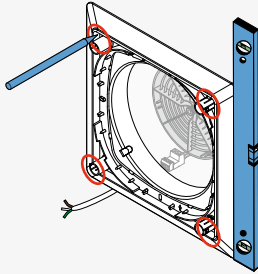

Requirements:

- The thermal accumulator insert has been installed.
- ▶ Position the inner cover adapter with the base plate inserted centrally to the wall sleeve on the interior wall.
- ▶ Align the inner cover adapter including the inserted base plate with a spirit level.
- ▶ Mark the four corner drill holes.
- ▶ Drill the four holes with $\varnothing 6 \text{ mm}$, min. 40 mm deep.
- ▶ Insert the rawl plugs.
- ▶ Route the fan BUS from behind through the cable entry of the prepared base plate.



NOTICE: If the base plate of the inner cover is twisted, the inner cover panel cannot be fitted correctly!

- The position arrow on the inner cover base plate must **always point upwards**.

- ▶ Screw the base plate into the rawl plugs with the screws.



The position arrow on the base plate points upwards.

⇒ The inner cover base plate is fitted.

4.8 Electrical connection of the reversible fan

The function of the iV-Office ventilation system requires the simultaneous operation of two iV-Office ventilation devices in push-pull mode. This section therefore describes the connection of a pair of devices, not a single device.



NOTICE

Incorrect electrical connection will damage the fan motor!

- Always connect the ventilation device to the mains supply via a controller.
- Ensure the correct sequence of the wire colours so that the fans start.



Stripping tool, screwdriver, blade, wire end ferrules (3 x 0.75 mm²)

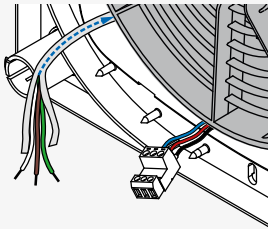

3 x 0.75 mm²

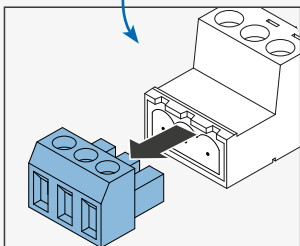
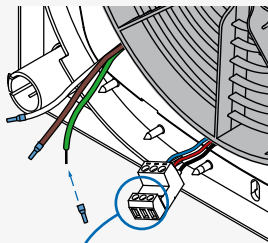

Requirements:

- The reversible fan is inserted into the wall sleeve.
- The base plate or inner cover holding plate is fitted.

▶ Shorten the fan BUS, 3-wire, to your determined wall thickness minus 200 mm.

▶ Remove the cable sheath from the fan BUS.



NOTICE: Using the wrong wire end ferrules to connect the cables in the plug-in connector will lead to a short circuit in the fan BUS!

- Use wire ferrules with collars to connect the wire strands.

▶ Press wire end ferrules onto the cables, cable cross-section 0.75 mm².

▶ Loosen the plug connections on the reversible fans of the two ventilation devices.

▶ Align the plug connectors on the ventilation devices so that the clamping screws on both are facing in the same direction (e.g. upwards).

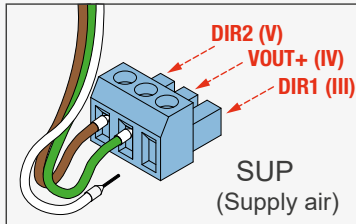
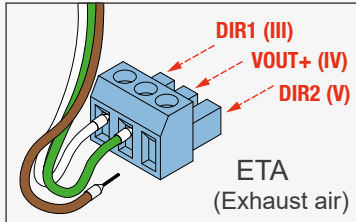

In paired operation, one reversible fan starts in extract air mode, the other in supply air mode. This start direction is determined by the different connection sequence of the three fan BUS cables in the plug-in connector.

► Secure the three fan BUS cables in the plug-in connector.



! Pair one with starting direction with exhaust air and the other with starting direction supply air.

Exhaust air mode:

- (White) cable DIR (III) in the left pole.
- (Green) cable VOUT+ (IV) in the middle pole.
- (Brown) cable DIR2 (V) in the right pole.

Supply air mode:

- (Brown) cable DIR2 (V) in the left pole.
- (Green) cable VOUT+ (IV) in the middle pole.
- (White) cable DIR1 (III) in the right pole.

► Reconnect the connected plug-in connector to the plug-in connector on the reversible fan.

Start direction extract air mode:

Start direction supply air mode:

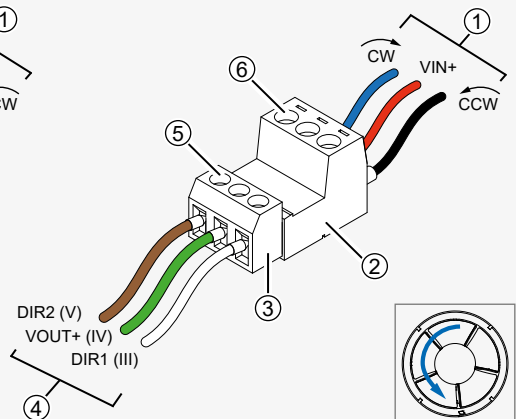
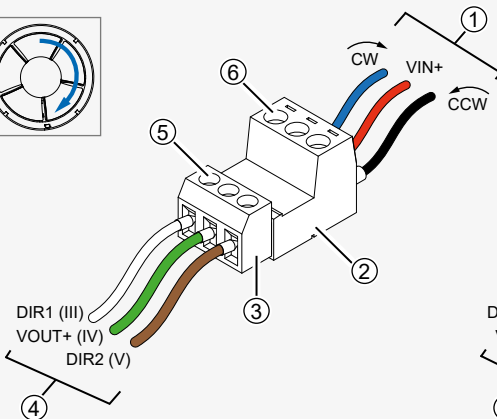
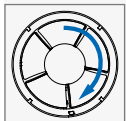

- The clamping screws of the plug connection are directed to the same side.
- The connections of the white and brown cable are swapped.

- 1 Fan cable [to the fan]
- 2 Plug-in connector on the fan cable
- 3 Plug-in connector on the controller cable
- 4 Fan BUS [to controller]

- 5 Clamping screws on the controller plug-in connector
- 6 Clamping screws on the fan plug-in connector

Plug-in connector on the fan cable		Plug-in connector (cable coming from controller)					
		Start direction extract air			Start direction supply air		
Terminal block	Colour	Terminal block	Meaning	Colour	Terminal block	Meaning	Colour
CW	Blue	DIR1 (III)	Signal direction 1	White	DIR2 (V)	Signal direction 2	Brown
VIN+	Red	VOUT+ (IV)	Operating voltage	Green	VOUT+ (IV)	Operating voltage	Green
CCW	Black	DIR2 (V)	Signal direction 2	Brown	DIR1 (III)	Signal direction 1	White

⇒ The reversible fan is connected to the controller.

4.9 Check function and complete fan installation

- ▶ Set unidirectional ventilation operating mode (DL - through ventilation) on the connected controller (see the controller's installation and operating instructions).
- ▶ Make sure that all reversible fans rotate in the direction appropriate to their connections.

Start direction extract air mode:

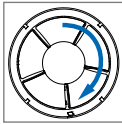

Direction of fan clockwise

Start direction supply air mode:

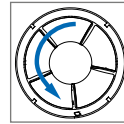

Direction of fan counter clockwise

⇒ inVENTron is connected and installed.

4.10 Installing the inner cover panel

The assembly of any internal termination variants is not part of this documentation!
It can be found in the separate installation instructions for the respective component.

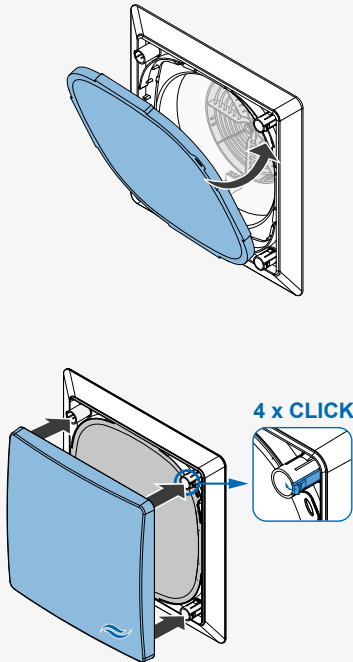

Requirements:



- The thermal accumulator insert has been installed.

Ensure you install the dust filter properly to avoid a malfunction of the ventilation device.

- ▶ Insert the dust filter into the base plate.
 - 👁️! • Push the filter ring firmly between the fixing tabs and the inner edge of the base plate.
 - 👁️! • The tab on the filter ring faces the inside and is located in the cut-out provided in the base plate.
 - ▶ Place the panel on the four spacers.
 - 👁️! The position arrows on the back of the inner cover panel point upwards.
 - Check:** The inVENTer logo is located at the bottom right
 - ▶ Press the locking lugs inwards on the spacers.
 - ▶ Slide the inner cover panel onto the spacers.
 - ⇒ All spacers noticeably snap in.
- ⇒ The inner cover panel is fitted.

5 Technical data

5.1 General specifications

Feature	Value
Operating range [°C]	-20 – 50
Minimum wall thickness [mm]	260
Extract air/outdoor air	Free from aggressive gases, dust and oils
Flow rate in reversed mode [m³/h]	10 – 45
Extract airflow [m³/h] (EN 13141-8)	20 – 90
Sound pressure level, distance 2 m [dB (A)]	14 – 41
Standard sound level difference [dB]	43 – 52
Thermal efficiency of heat recovery (η_w)	0.88
Input voltage [V DC]	6 – 16
Power consumption [W]	1 – 5
Specific fan power input [W/(m³/h)]	0.14
Protection class (EN 61140)	III
Type of protection (EN 60529)	IP20
Standard filter filter class ISO 16890 EN 779:2012	ISO Coarse 60 % G4
Sensitivity of the air flow at ± 20 Pa (EN 13141-8)	S2
Electrical protection area (in accordance with VDE 0100)	Outside protection areas 0 – 2
Frost protection	Automatic by reversing operation (down to -20 °C)
Conformity	 

5.2 iV-Office energy label according to ErP Directive, Regulation 1254/2014

On the energy label you will find the following information from the product data sheet:

- Energy efficiency class (SEC class)
- Sound power level L_{wa}
- Maximum air flow (supply air)

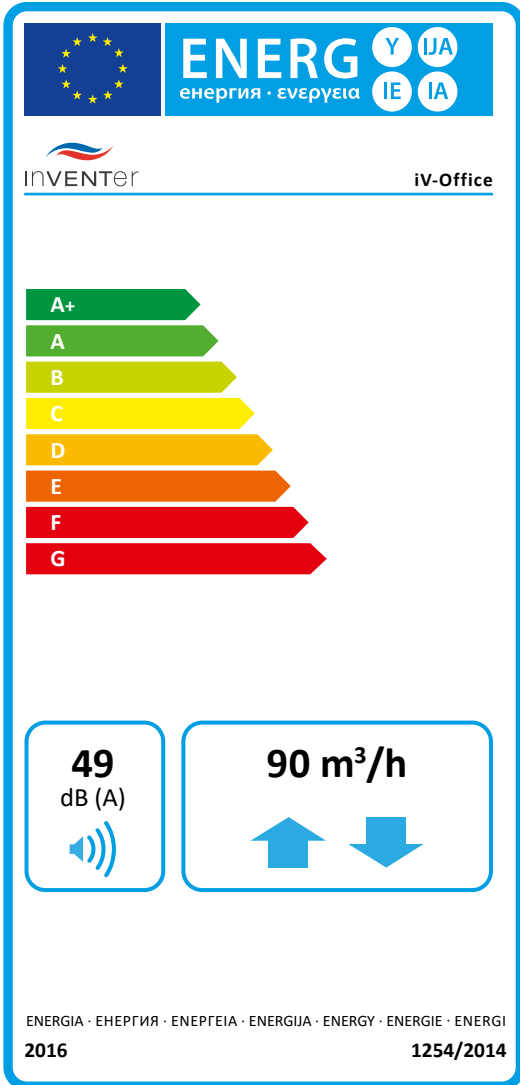

Demand-controlled	Manually controlled
Pure with sensors sMove with sensors Easy Connect e16 MZ-Home	Pure without sensor sMove without sensor

5.3 Specifications according to ErP Directive, Regulation 1254/2014

iV-Office ventilation device, demand-controlled:

 iV-Office product data sheet according to EU Ordinance 1254/2014 dated 11 July 2014			
Pt	Description	Values	
a	Supplier	inVENTer GmbH	
b	Model identifier	iV-Office	
c	SEC class / Specific Energy Consumption (SEC) [kWh/(m ² a)]	Cold	-88.481
		Average	A+ -44.234
		Warm	-18.886
d	Ventilation type	BVU	
e	Type of drive	2	
f	Type of heat recovery system	Regenerative	
g	Degree of temperature change η_t [%]	88	
h	Maximum air flow rate [m ³ /h]	90	
i	Electrical input power (incl. control) [W]	9	
j	Sound power level L _{wa} [dB (A)]	49	
k	Reference air flow [m ³ /h]	63	
l	Reference pressure difference [Pa]	0	
m	SEL [W/m ³ /h]	0.14	
n	Control factor	0.65	
o	Internal and external transfer [%]	n. a.	
p	Mixing quota [%]	n. a.	
q	Position and description of the indicator for filter change	Control device	
r	Instructions regarding controllable supply and extract air grilles on the façade (unidirectional ventilation devices only)	None	
s	Internet address	www.inventer.de	
t	Sensitivity to pressure changes [%]	17.8	
u	Airtightness between interior and exterior [m ³ /h]	6.3	
v	Annual power consumption [kWh/(m ² a)]	0.82	
w	Annual savings Heating energy [kWh/(m ² a)]	Cold	90.61
		Average	46.32
		Warm	20.94

iV-Office ventilation device, manually controlled:

 iV-Office product data sheet according to EU Ordinance 1254/2014 dated 11 July 2014			
Pt	Description	Values	
a	Supplier	inVENTer GmbH	
b	Model identifier	iV-Office	
c	SEC class / Specific Energy Consumption (SEC) [kWh/(m ² a)]	Cold	-82.817
		Average	A -39.977
		Warm	-15.435
d	Ventilation type	BVU	
e	Type of drive	2	
f	Type of heat recovery system	Regenerative	
g	Degree of temperature change η_t [%]	88	
h	Maximum air flow rate [m ³ /h]	90	
i	Electrical input power (incl. control) [W]	9	
j	Sound power level L _{wa} [dB (A)]	49	
k	Reference air flow [m ³ /h]	63	
l	Reference pressure difference [Pa]	0	
m	SEL [W/m ³ /h]	0.14	
n	Control factor	1	
o	Internal and external transfer [%]	n. a.	
p	Mixing quota [%]	n. a.	
q	Position and description of the indicator for filter change	Control device	
r	Instructions regarding controllable supply and extract air grilles on the façade (unidirectional ventilation devices only)	None	
s	Internet address	www.inventer.de	
t	Sensitivity to pressure changes [%]	17.8	
u	Airtightness between interior and exterior [m ³ /h]	6.3	
v	Annual power consumption [kWh/(m ² a)]	1.93	
w	Annual savings Heating energy [kWh/(m ² a)]	Cold	87.78
		Average	44.87
		Warm	20.29

6 Scope of supply

Standard components

All standard components are also available as spare parts. Further accessories and spare parts can be found in the separate accessories overview.

Contact your local distributor to order accessories for your ventilation system

Component	Item number
iV-Office	1001-0213
Standard variant external termination ²⁾ : Weather protection hood including sealing tapes	
Flex-Office weather protection hood, white – RAL 9016	1508-0181 1508-0185 ¹⁾
Flex-Office weather protection hood, grey – RAL 9006	1508-0182 1508-0186 ¹⁾
Flex-Office weather protection hood, Nord – RAL 7011	1508-0184
Flex-Office weather protection hood, anthracite – RAL 7016	1508-0183 1508-0187 ¹⁾
Flex-Office weather protection hood, custom colour	1508-0190 1508-0188 ¹⁾
Wall sleeve with styrofoam discs and mounting wedges	
Wall sleeve R-D250x495	1506-0072
Wall sleeve R-D250x745	1506-0073
Thermal accumulator insert	
iV-Office thermal accumulator insert [incl. Inventin 495 mm]	1507-0028
iV-Office thermal accumulator insert [incl. Inventin 745 mm]	1507-0029
Inner cover	
Flair XL V-280x280 inner cover, white, incl. SDE	1505-0050

¹⁾ Special variant: consisting of aluminium, with increased salt resistance

²⁾ Item numbers of any external termination variants in the separate installation instructions of the respective external termination.

7 Troubleshooting

Troubleshooting

Fault	Possible cause	Remedy
Fan failure	No electrical power.	Check fuse.
	Installation error.	Check wiring for correct polarity. Check all connectors for correct fit. Check the use of wire ferrules.
	Fan defective.	Replace fan.
	Controller/power supply defective.	Switching controller/power supply.
Fan does not switch off.	Faulty controller.	Replace controller.
Low flow rate	Panel closed.	Open panel.
	Fans are not operating in paired mode.	Connect the first fan in extract air mode and the second fan in supply air mode.
	The rotational speed of the fan is too low.	Increase the output level.
Noises	Foreign body in the fan.	Remove foreign body from the fan. Clean the ventilation system.
	Thermal accumulator is not correctly positioned in the wall sleeve.	Slide the thermal accumulator out of the wall sleeve. Insert it again. Slide the thermal accumulator into the wall sleeve as far as the end-stop tape.
	The rotational speed of the fan is very high.	Set a lower output level on the controller.
Supply air is cold	Installation error.	Make sure that the device label on the Xenion EFP fan is directed towards the thermal accumulator.
		Check the connector plug on the controller. The connector plug must be sitting firmly in the connector housing.
	The controller is operating in ventilation mode.	Select heat recovery mode on the controller.

8 Warranty and guarantee

Warranty

Outside Germany, the national warranty provisions of the country in which the system is sold apply. Please contact the distributor for your country.

The warranty covers all defects that were present at the time of purchase. Failure to observe the intended use will invalidate all warranty claims.

Manufacturer guarantee

inVENTer GmbH provides a five-year guarantee for all electrical components and the wall sleeve, as well as a thirty-year guarantee on the ceramic component of the thermal accumulator. This covers premature product wear.

Further information about the warranty is available at www.inventer.eu/guarantee

9 Service

Claims

Check the delivery for completeness and transport damage upon receipt using the delivery note. Report missing items immediately, and at the latest within 14 days to your supplier, distributor or factory representative.

Warranty and guarantee claims

In the case of a warranty or guarantee claim, contact your local distributor or factory representative.

In all cases, please return the complete device to the manufacturer.

The warranty is an additional offering by the manufacturer and in no way affects the applicable law.

Accessories and spare parts

To order components for your ventilation device, contact your nearest distributor or our service staff.

Technical customer service

For technical support contact our service staff:



+49 (0) 36427 211-0



+49 (0) 36427 211-113



info@inventer.de



<http://www.inventer.eu>

inVENTer GmbH
Ortsstraße 4a
D-07751 Löberschütz
Germany
www.inventer.eu

Subject to modifications.
We accept no liability for printing errors.

Item number: 5001-0043
Version: 2.0 – 06/2022

