

INSTALLATIEHANDLEIDING

AT-TEC LUCHT WATER WARMTEPOMP SPLIT



Technea Duurzaam

Exclusief distributeur AT-Tec warmtepompen

058 – 288 47 39 | info@technea.nl | www.technea.nl

TABLE OF CONTENTS

1. INTRODUCTION	5
1.1. General information.....	5
1.2. Content of this document.....	5
1.3. Not included in this document	5
1.4. Additional documents.....	5
1.5. Required tools.....	5
2. GENERAL INFORMATION	5
3. TRANSPORT INSTRUCTIONS	6
4. SAFETY INFORMATION	6
5. INTEND USE OF THE HEAT PUMP	7
5.1. Fields of work and safety devices	7
6. EQUIPMENT OF SUPPLY	7
6.1. Main components.....	7
6.2. Inspection	7
6.3. Exploded view of WPL412, WPL618.....	8
6.4. Exploded view of AV412, AV618.....	9
7. INSTALLATION	10
7.1. Measures of the device	10
7.2. Free spaces for assembly	12
7.3. Alignment of the heat pump	12
7.4. Installation guidelines	13
7.5. Preperation of condensate drain.....	13
7.6. Installation manual condensate tray for AV412 and AV618.....	15
8. HYDRAULIC CONNECTIONS	17
8.1. Installation of hydraulic part	17
8.2. Correct refilling of the heating system.....	18
9. REFRIGERANT CONNECTIONS	18
10. ELECTRICAL CONNECTIONS	19
10.1. General Information.....	19
10.2. Supply	19
10.3. Power supply connections.....	20
10.4. Wiring diagram of interface.....	23
10.5. Wiring diagram of extension Z201	24
1.1. Wiring diagram of heating circuit module IM110	27
10.6. Connection of the Controller AP420 for wall mounting.....	29
10.6.1. Mounting	30
10.6.2. Connections and wiring	31
10.7. Connection of the Controller OI420	34
10.7.1. Montage.....	35
10.7.2. Connections and wiring	36
10.7.3. Assign to heating circuit.....	38
10.7.4. Operating.....	38
11. OPERATION AND DISPLAY	39
11.1. User level	39
11.2. Display and operating elements	39
11.3. Visibility	40

12. OPERATING MASKS - EASY	41
12.1. Start mask home.....	41
12.2. Mask settings	42
12.3. Basic layout of the settings menu	42
12.4. Heating circuits	43
12.5. Hot water	45
12.6. Vacation	45
12.7. Select system operating mode.....	46
12.8. Chimney Sweeper	46
12.9. Device.....	47
12.10. Mask help	48
13. OPERATING MASKS - EXPERT	48
13.1. Basic layout of the detail menu	48
13.2. Alarms	49
13.3. Time, Date.....	50
13.4. Service.....	50
13.5. Save/Load parameters.....	50
13.6. Network	52
13.7. Remote maintenance	53
13.8. Restart.....	53
13.9. Data logging	53
13.10. USB Data logging	53
13.11. Status report	54
13.12. Diagnostics	54
13.13. Event log	55
13.14. Notification	55
13.15. System information.....	56
13.16. Software update	56
13.17. Factory settings.....	56
13.18. Charts.....	57
14. SYSTEM SCHEMES	58
14.1. General system schema.....	59
14.2. Extended system schema	60
15. INITIAL OPERATION	67
16. COMMISSIONING	67
16.1. Commissioning AP420	67
16.2. Commissioning OI420.....	67
16.3. Setup assistant.....	68
16.4. Set-up of heating generator and heat distributing.....	70
17. MANUAL MODE	71
17.1. Testing of the sensors and actuators with manual mode	71
18. ALARMS AND EVENTS	72
19. WEB APPLICATION	88
19.1. Tested platforms and web browsers	88
19.2. Connection PC to operating unit	88
19.3. Connection smart phone to operating unit.....	88
19.4. Connection setup via remote access outside the local network	89
20. PREPARE USB STICK FOR SERVICE FUNCTIONS	90
21. HANDOVER TO END CUSTOMER	90

22. CLEANING AND CARE.....	90
23. WARRANTY INFORMATION.....	92
24. DISPOSAL.....	92
25. SAFETY DATASHEET	93
26. DECLARATION OF CONFORMITY	FOUT! BLADWIJZER NIET GEDEFINIEERD.

1. Introduction

Congratulations on your purchase of a quality product from AT-Tec!

1.1. General information

This document is aimed both at heating engineers who install AT-Tec heat pumps and at end customers who operate a AT-Tec heat pump. Please read this document carefully.

1.2. Content of this document

This manual is part of the product. It should be kept for the entire service life of the product and, if required, passed on to any subsequent owners or users of the product.

All the figures used in this manual are example graphics!

1.3. Not included in this document

Information on planning and servicing the system.

Instructions on how to set the correct parameters on the controller.

1.4. Additional documents

- AT-Tec TDS software

1.5. Required tools

- 1 set of cross and slotted screwdrivers
- Side cutter
- Scissors
- 1 set of wrenches or pipe wrenches
- Ladder
- Plumbing material for sealing the threads
- Equipment for electrical connections
- Protective gloves
- Tester and current tongs

2. General Information

The ECOAir Premium heat pump is a series of machines full- inverter that is with high performance components and widely dimensioned to privilege the efficiency of the machine.

The use of the gas R410A permits to reach high performances and a low environmental impact. The presence of two electronic valves, reversing valve, pressure transducers and temperature sensors ensure, through the software integrated in the electronic board as microprocessor, the full functionality and reliability of the machine in the different operating regimes.

The control of the machine is done through a remote control that permits to monitor the operation of the machine and change the temperature set of the water produced and the mode of operation (summer/winter).

3. Transport instructions

During the transport it is possible to tilt the heat pump no more than 45° (in each direction). The safety for the transport has to be removed before of the put in action. The aspiration and unloading zone mustn't be reduced or covered. Respect specific building regulations of each countries.

The dirt trap, not included but supplied on demand of the customer, must be assembly on the heating return upstream of the heat pump.

Respect the regulations in force for the countries concerned.

Respect the right-handed rotation field: in case of incorrect wiring the start of the heat pump is hindered. The programmer of the heat pump shows the relevant warning indication (to correct the wiring).

The operation of the heat pump with too low temperature system can cause its total block. After a prolonged power cut you have to use the method of put in action described below.

Clean at regular intervals the dirt trap.

Before opening the device cut off power to all the electrical circuits.

Works on the heat pump can be done only by authorized and competent people of the customer care.

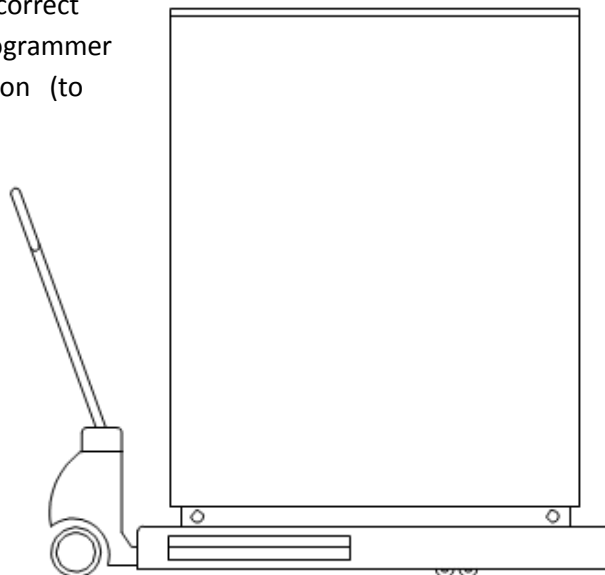

4. Safety information

Observe the following points to ensure the reliable, safe and trouble-free operation of the heating heat pump:

Installation and initial operation of the heat pump system is restricted to the experts of AT-Tec and its partners. Before starting work, disconnect the power supply to the system, ensure that no voltage is present and safeguard against unintentional reconnection. Observe the prevailing guidelines, standards and regulations that are applicable for use, even if these are not stated in this document.

These include:

- Universally applicable accident prevention regulations
- Safety requirements
- Environmental requirements
- All relevant laws, standards, guidelines and regulations
- Requirements of the local power supply utilities

All maintenance and repairing activities concerning the heat pump system are restricted to the experts of AT-Tec and its partners. Ensure clockwise rotation. The compressor may be damaged if constantly rotated in the wrong direction! It is not allowed to use the heat pump system for purposes other than the ones determined by the contract.

It is also prohibited to use system components for purposes other than their intended tasks. Modifications on the heat pump system, whatsoever, are acceptable only after consultation with AT-Tec and can be carried out only by experts of AT-Tec or its partners.

To prevent deposits (e.g. rust) in the condenser of the heat pump, use of a suitable anti-corrosion system is recommended. In case of a breakdown of the heat pump system (high pressure failure, low pressure failure or limit temperature reached) and in case of frost danger in the building, the heat pump system switches to antifreeze mode. Is the heat pump installed in not permanently inhabited buildings (e.g. summer residences), the user is responsible for keeping the system frost-free.

If refrigerant is leaking from any part of the heat pump system – whatever the reason might be – take care of adequate aeration and avoid handling with open light or fire. Leave the danger zone immediately and notify AT-Tec.

5. Intend use of the heat pump

5.1. Fields of work and safety devices

The application limits for the individual heat pump types can be found in the respective technical data sheet.

The ECOAir Premium heat pump is equipped with a safety pressure switch that stop the operation of the machine when a pressure of 4,2 MPa (42 bar) is reached. The heat pump is equipped with a frost protection system which prevents freezing of the water pipes connected to the heat pump at low outside temperatures. When the frost protection is activated, the circulating pump remains ON, even if the heat pump is set to OFF. The machine remains in the standby state when the protection is active and therefore could start up if conditions require it (even if it is in the OFF state). The basis for this is the connection of the control voltage.

6. Equipment of supply

6.1. Main components

The heat pump is supplied on a pallet.

6.2. Inspection

The delivery consists of the heat pump module with Integrated central control.

Please check the system for completeness and damage immediately after receipt of the heating heat pump!

If necessary, tighten the hydraulic connections on the heat exchangers as they are provided with paper seals and may, under certain circumstances, reduce their design.

Please see the delivery note for the exact scope of delivery. If you notice any damage or the delivery is incomplete, please inform AT-Tec immediately, as a complaint will not be possible at a later date.

6.3. Exploded view of WPL412, WPL618

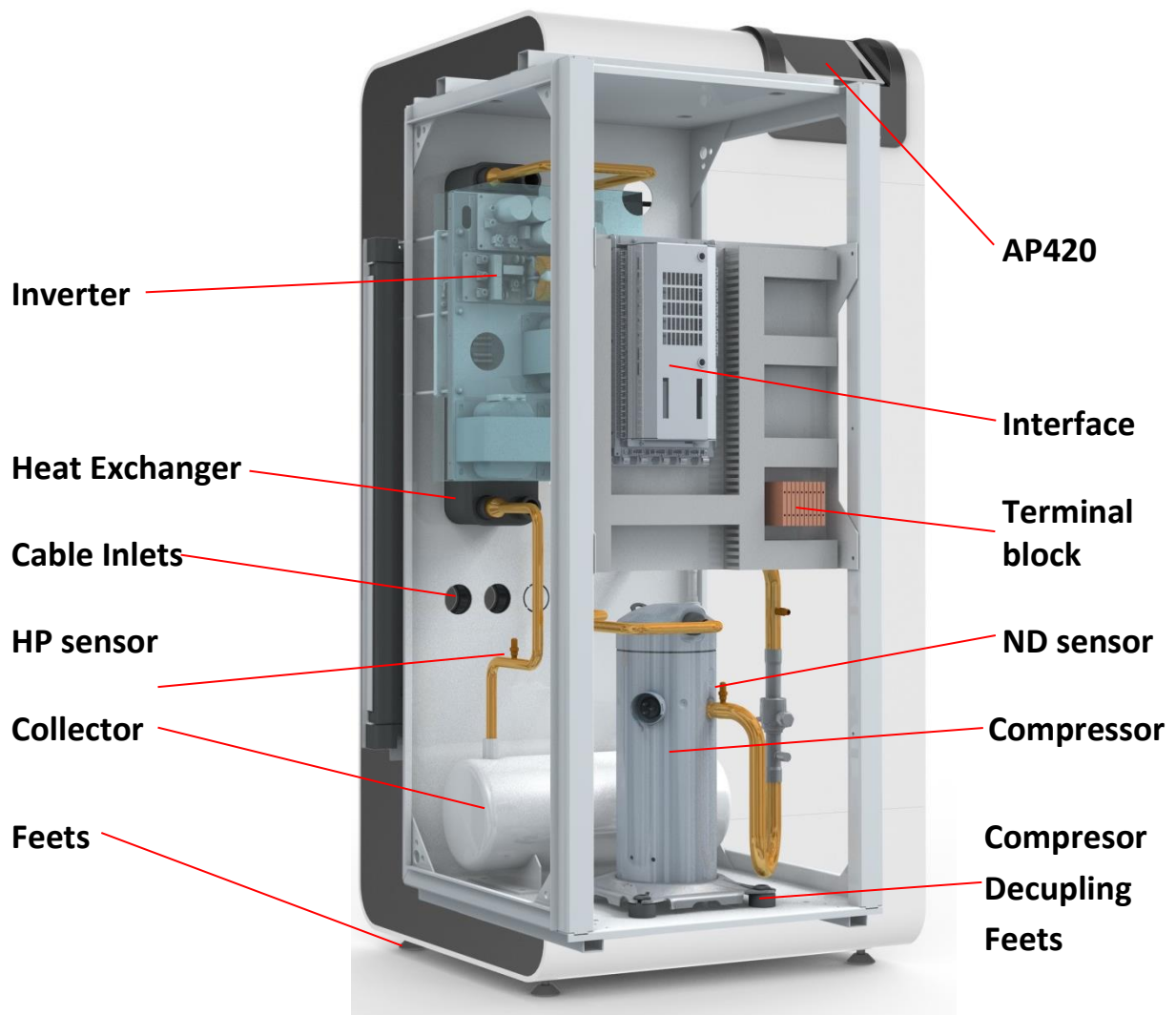

6.4. Exploded view of AV412, AV618

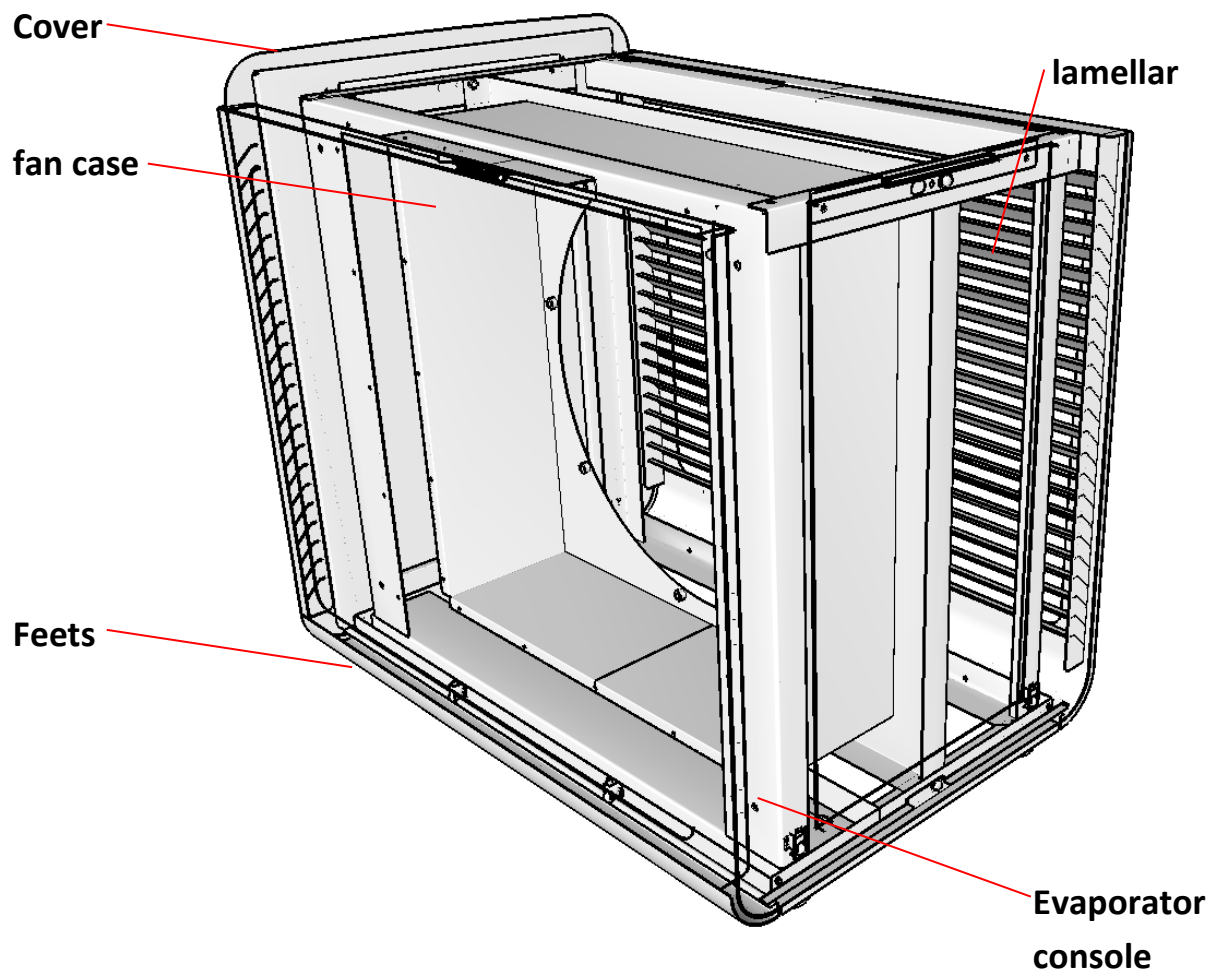

7. Installation

7.1. Measures of the device

WPL412, WPL618

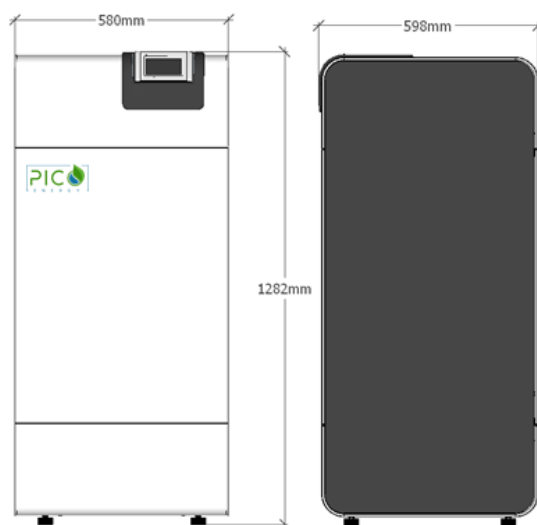

AV412

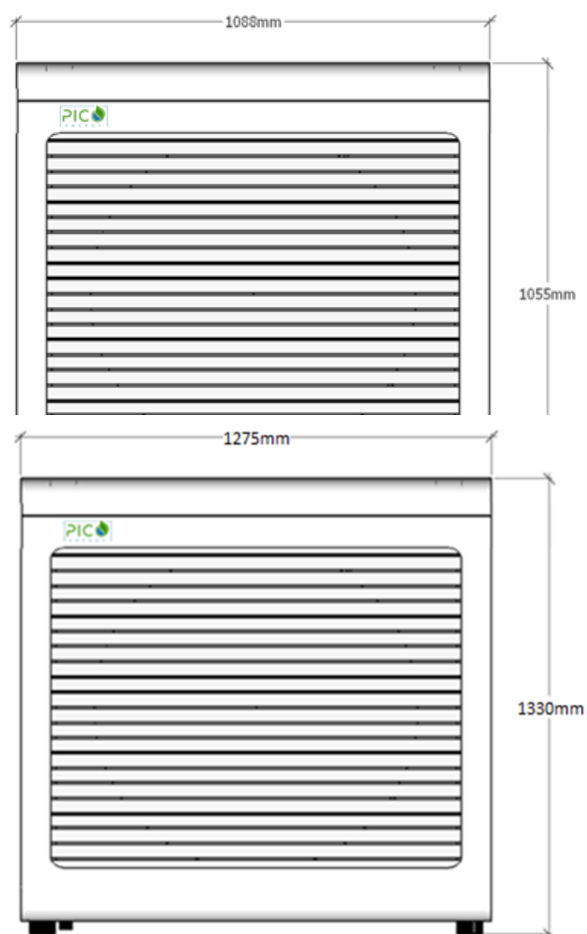
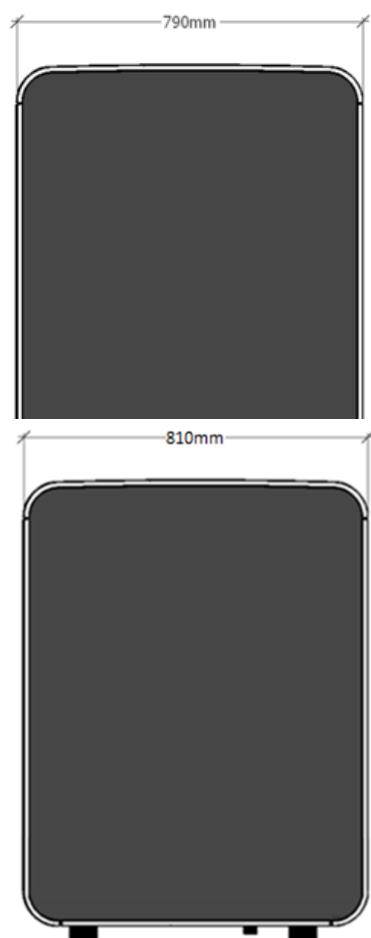

AV618

7.2. Free spaces for assembly

Verify there is a sufficient space for the installation of the hydraulic piping.

This product was developed for indoor usage and installation only.

Distance	Measures
A	>400mm
B	>400mm
C	>200mm
D	>600mm
E	>400mm

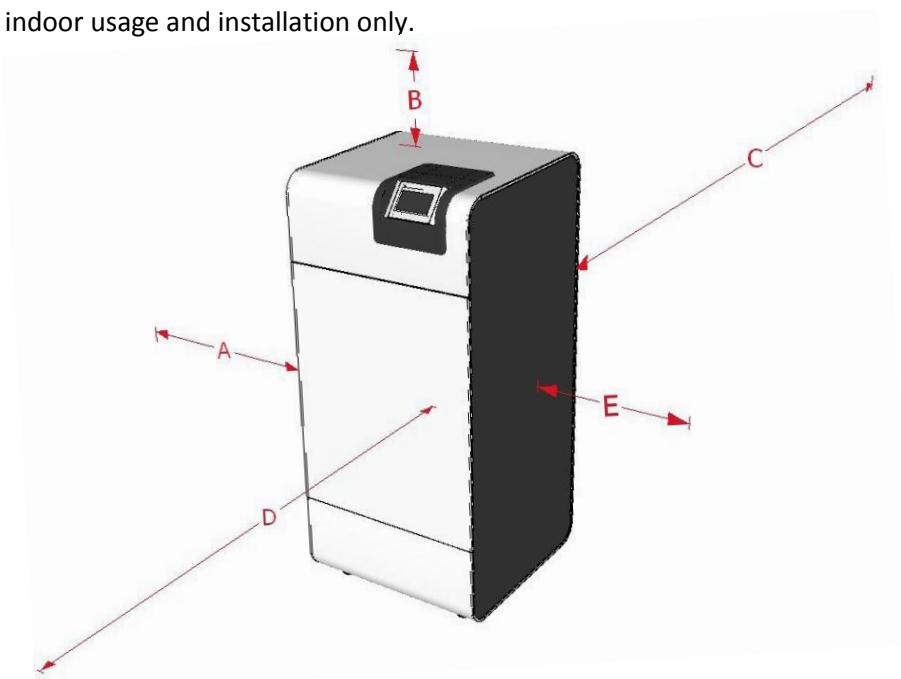

Distance	Measures
A	>800mm
B	>400mm
C	>400mm
D	>3000mm
E	>800mm

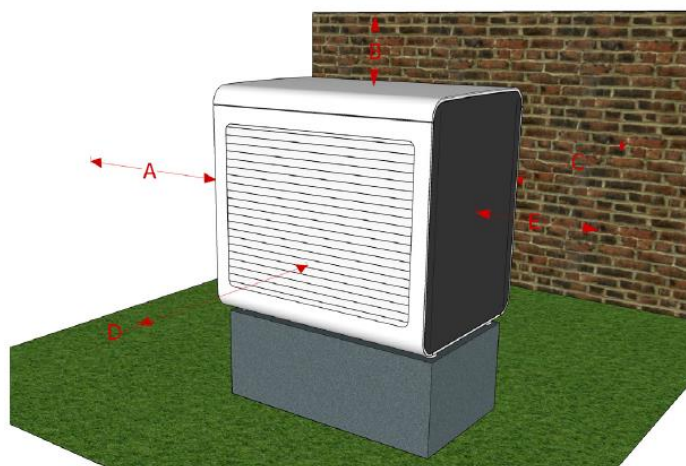

7.3. Alignment of the heat pump

Put horizontally the heat pump ECOAir Premium so that the condensate can flow. The product must be installed with amortized feet, purchased separately. The amortized feet increase the height of the product, facilitating the flow of condensate and reducing vibrations.

7.4. Installation guidelines

- Observe all the rules in force.
- Install the product outside the building.
- Don't install the product:
 - near a heat source,
 - near flammable substances,
 - near ventilation opening of contiguous buildings,
 - below deciduous trees.
- For the installation of the product observe:
 - prevailing winds,
 - noise of the fan and the compressor,
- Avoid place where on the air outlet of the product there is the effect of strong winds.
- Don't orient the fan towards the near windows.
- If necessary, install noise-protection system.
- Install the product on one of the following supports:
 - Concrete pavement,
 - T steal beam
 - Concrete block.
- Don't expose the product to dusty and corrosive air (e.g. near rough roads).
- Don't install the product near wells of air discharge.
- Prepare the laying of electrical cables.
- In places where there are snowfalls, install the heat pump at least 25 cm from the ground to avoid clogging at the inlet and drain zone.

7.5. Preperation of condensate drain

The condensate is discharged in a centralized way from the back of the heat pump ECOAir Premium. Prepare the condensate drain through a drain pipe or a gravel bed.

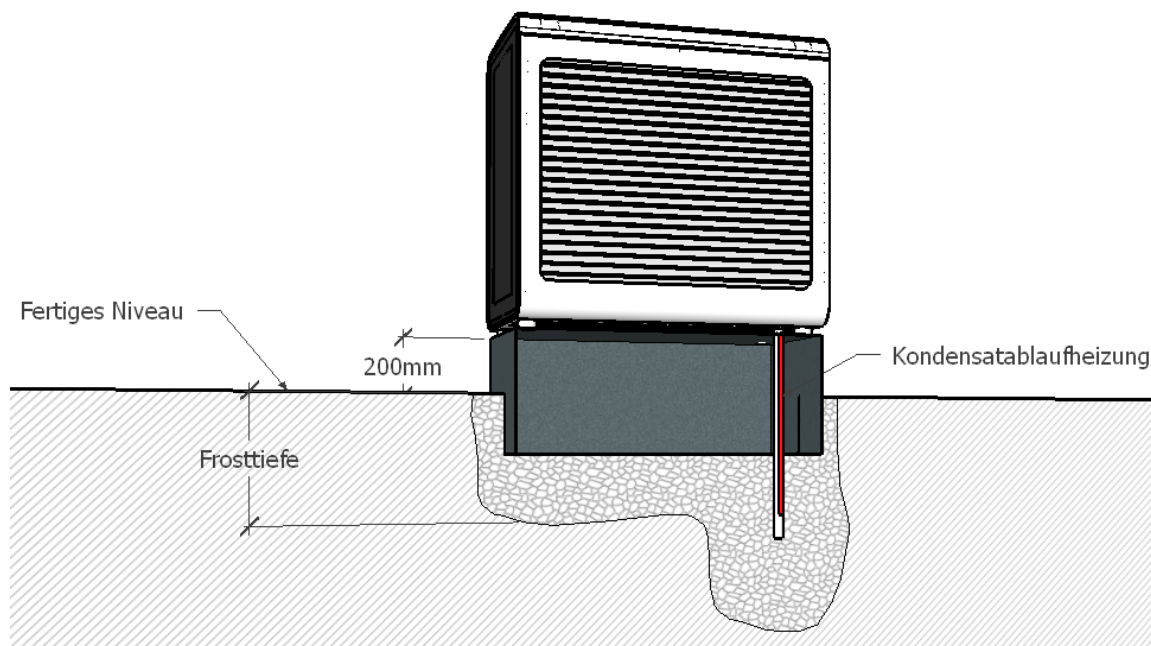

nsate drain

If the condensate tray is used, the accumulated water is collected there and discharged centrally via a drain. The condensate tray and the drain must be heated to do this.

7.6. Installation manual condensate tray for AV412 and AV618

(Art. Nr. 738131 und 738132)

Mounting position

In order to ensure a reliable drainage of the resulting condensate, the evaporator must be aligned horizontally.

Installation

The condensate tray is screwed in the evaporator directly under the lamella pack.

Installation instructions

The condensate tray heating is already installed in the condensate tray as shown in Figure 1.

Insert the entire tray into the side of the evaporator (Figure 2) under the lamella pack. Then fix the tub to the points marked as in "electrical allocation"

- The unheated connection pipe is marked with „* * * *“.
- The position between unheated connection pipe and

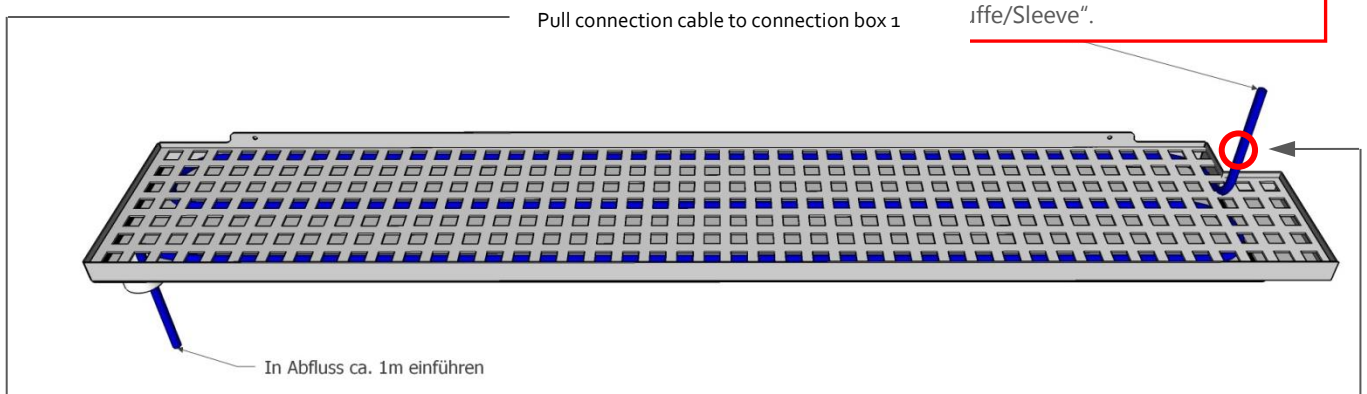

Figure 1

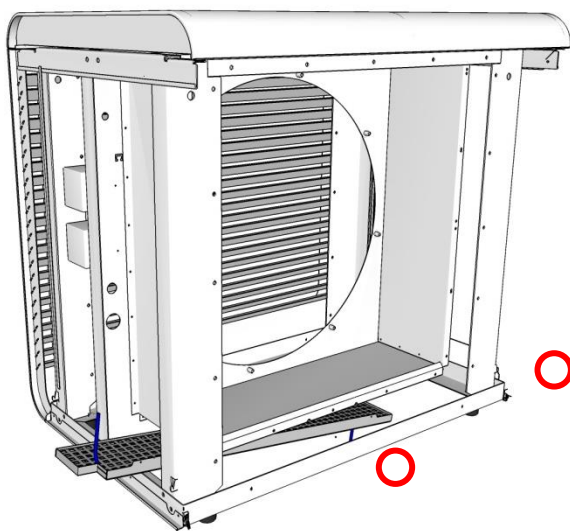

Figure 2

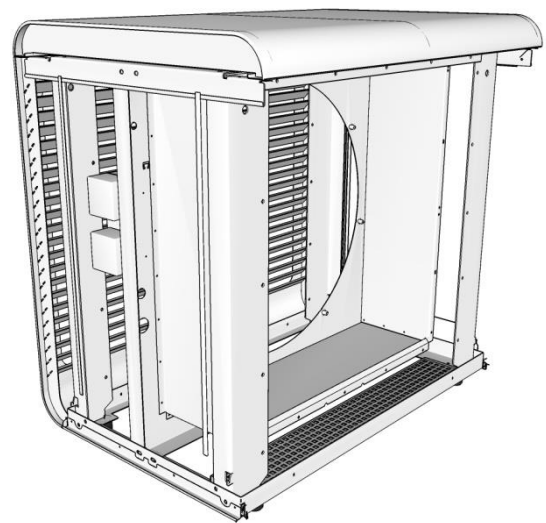
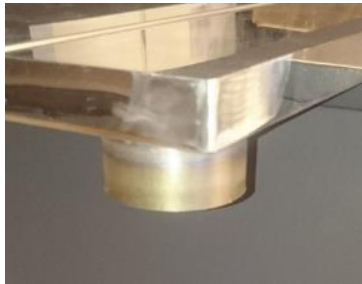

Figure 3

Drain dimension

The drain is made in dimension DN50 and is pushed onto the provided connection piece.



When connecting the condensate drain to the sewer system is necessarily a sufficiently sized to provide a siphon!

Electrical allocation

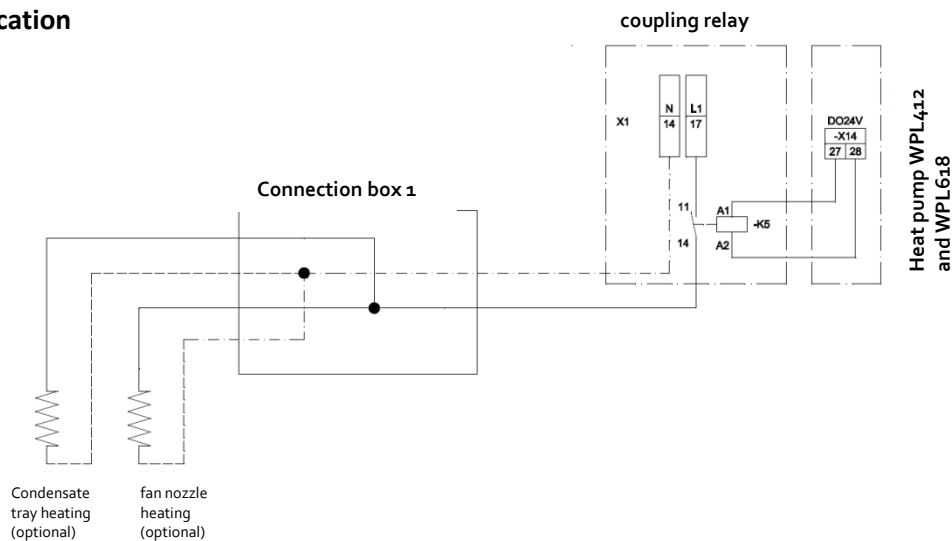

Funktionalität / Controller settings

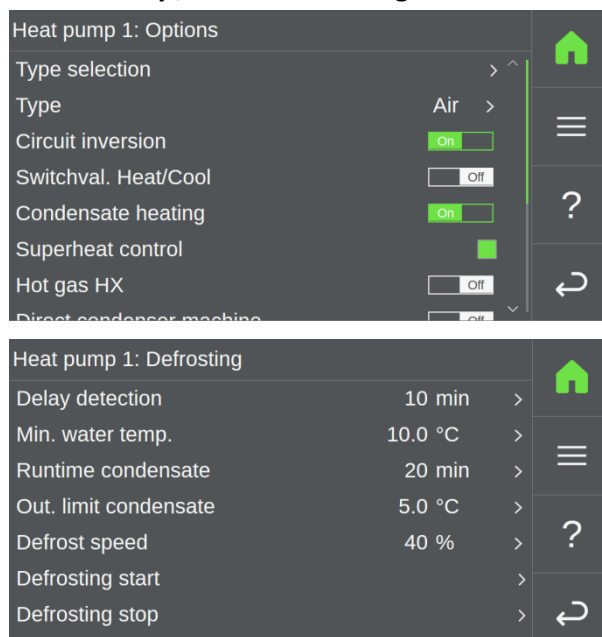

After successful installation, the regulation must indicate the presence of the condensate pan or its heating. To do this, activate the Condensate drain heating option under the heat pump options.

The heater is thus activated at each defrost and runs for an adjustable time. The duration can be set for the heat pump parameters under defrost.

8. Hydraulic connections

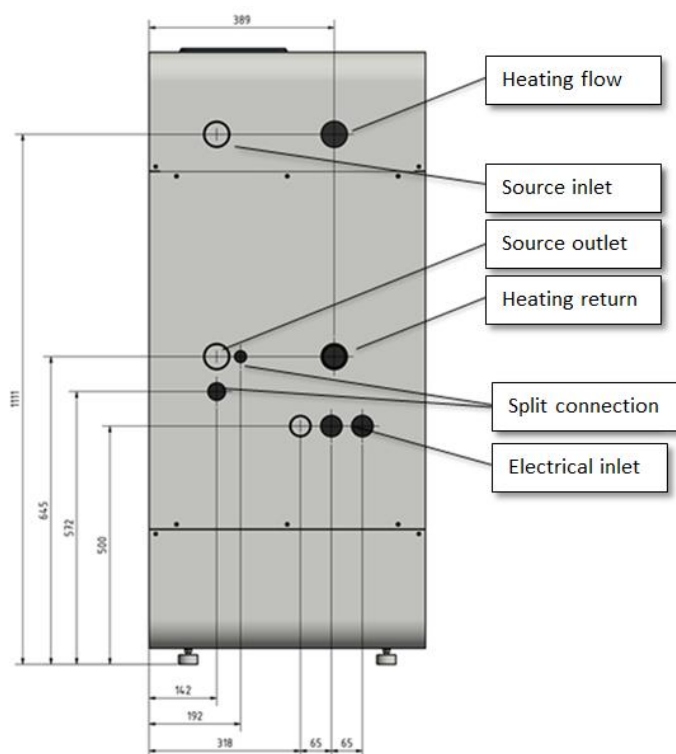

8.1. Installation of hydraulic part

- Thorough washing of the system with clean water filling and emptying it many times. This operation allows to reduce the number of maintenances and avoid damages to exchangers and other components.
- Test of possible losses in the circuit;
- Insulate all the pipelines to reduce heat losses and avoid the formation of condensation;
- Free up the service points like wells vents etc...;
- Verify that the quality of the water is suitable, contrary:
performance penalty, higher loading losses, possible damages

If there is the risk of water freezing in the system take the following preventive measures:

- Always powered machine for frost protection.
- Mix water with ethylene glycol or propylene glycol considering that the pressure losses increase and you have to verify the compatibility of all the hydraulic parts of all these compounds.
- In case of long stops completely empty the system opening all the cocks and pay attention to avoid water stagnation points.

8.2. Correct refilling of the heating system

During the operation of the heat pump system a pressure drop in the heating system can occur. The reason is often leaking air that has not been removed completely at the initial operation.

If the pressure of the heating system falls under 1.5 bar replenishment is necessary.

IMPORTANT

The replenishment must be done exclusively with treated heating water. The treatment must be carried out according to the applicable national standards, regulations and guidelines!

Fill water into the heating system until the manometer on the connection group displays 2.2 bar.



9. Refrigerant connections

The refrigerant connections for the split pipes are as follows :

WPL 412 und 618

Suction pipe: 22mm

Injection pipe: 12mm

Evaporator AV412

Suction pipe: 22mm

Injection pipe: 12mm

Evaporator AV618

Suction pipe: 22mm

Injection pipe: 15mm

10. Electrical connections

10.1. General Information

CAUTION

Before starting work, disconnect the power supply to the system, ensure that no voltage is present and safeguard against unintentional reconnection. Work on electrical systems may only be carried out by authorised and trained electricians.

Firstly, ensure that the power supply from the building was correctly relayed to the installation site and that the cable cross-section is adequate for the starting current and operating current.

Check that all electrical connections are tight. It is essential to ensure that the voltage connected for the supply matches the voltage that the machine is designed for.

WARNING

The wiring must comply with all applicable regulations. The type and position of the fused isolators must also comply with regulations. For safety reasons, these must be clearly visible and installed within operating distance of the machine. All machines must be earthed throughout.

IMPORTANT

Operating a machine with the wrong voltage or with excessive phase asymmetry represents incorrect use, which is excluded from the AT-Tec guarantee. If the phase asymmetry exceeds 2 % (voltage) and 1 % (current), please contact your power supply utility immediately, before commissioning the heat pump.

10.2. Supply

Connect the supply of the machine to the internal terminal block according to the scheme shown below. The cable routing occurs through the special holes as shown in the previous schemes.

APPROXIMATE section of cables and internal protection:

	ECOAir Premium 230V	ECOAir Premium 400V
Supply compressor Supply Interface	230V - 50 Hz 230V - 50 Hz	400V - 50 Hz 230V - 50 Hz
Compressor Cable Interface Cable	3x 6 mm ² 3x 1,5 mm ²	5x 2,5 mm ² 3x 1,5 mm ²
Protections of compressor Protections of Interface	1x C25 1x B13	3x C16 1x B13

10.3. Power supply connections

Get access to the terminal block inside the unit by removing the frontplate of the case. Now insert the cables to the inlets **1** at the backplate of the case and connect it with the terminal block **2**. Use the cable ducts as good as possible and cable ties or similar to fix the wires on pipes or parts except the compressor or heat exchangers.



Connect the main power supply for ECOAir Premium 400V units according to the following wiring diagram.

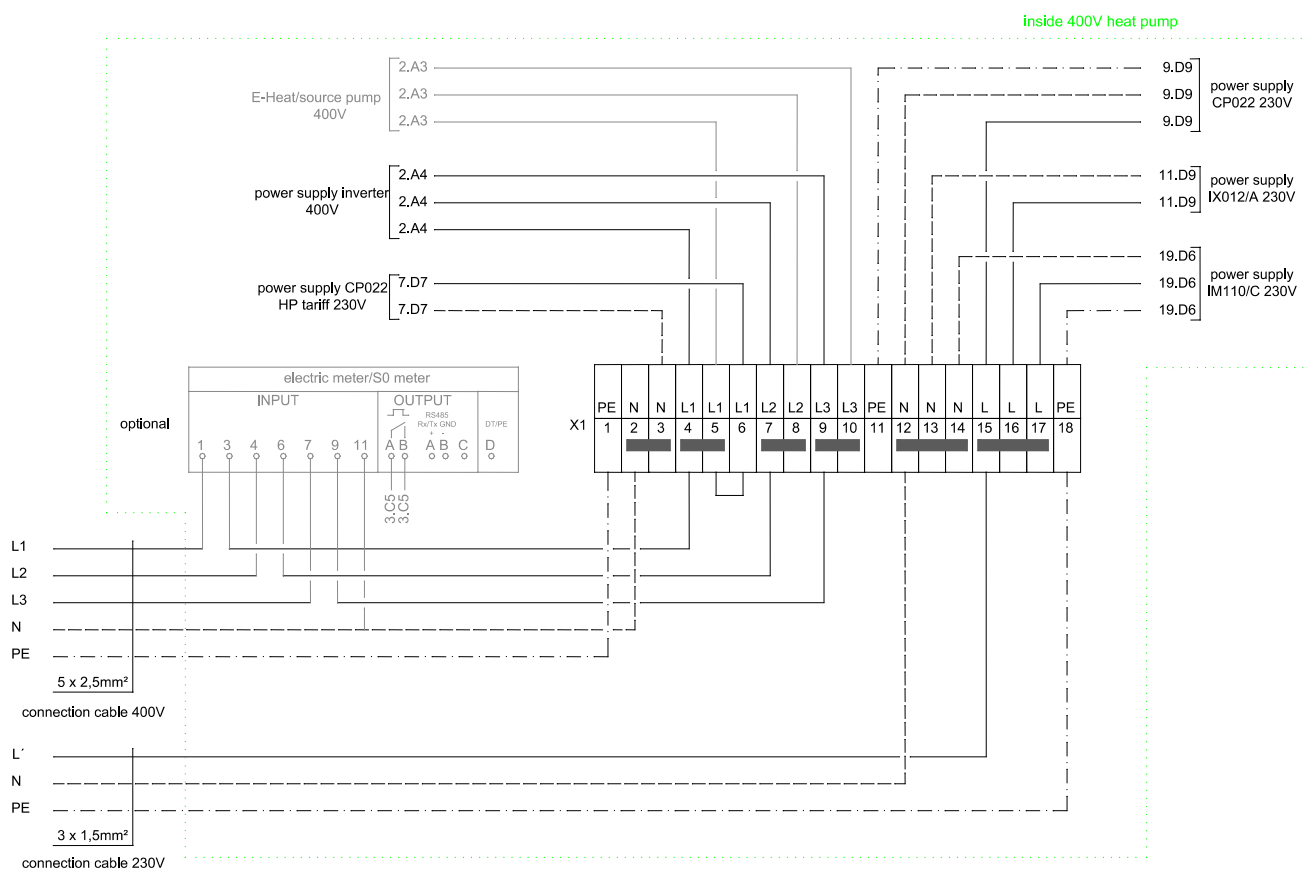

Connect the main power supply for ECOAir Premium 230V units according to the following wiring diagram.

inside 230V RuralECO

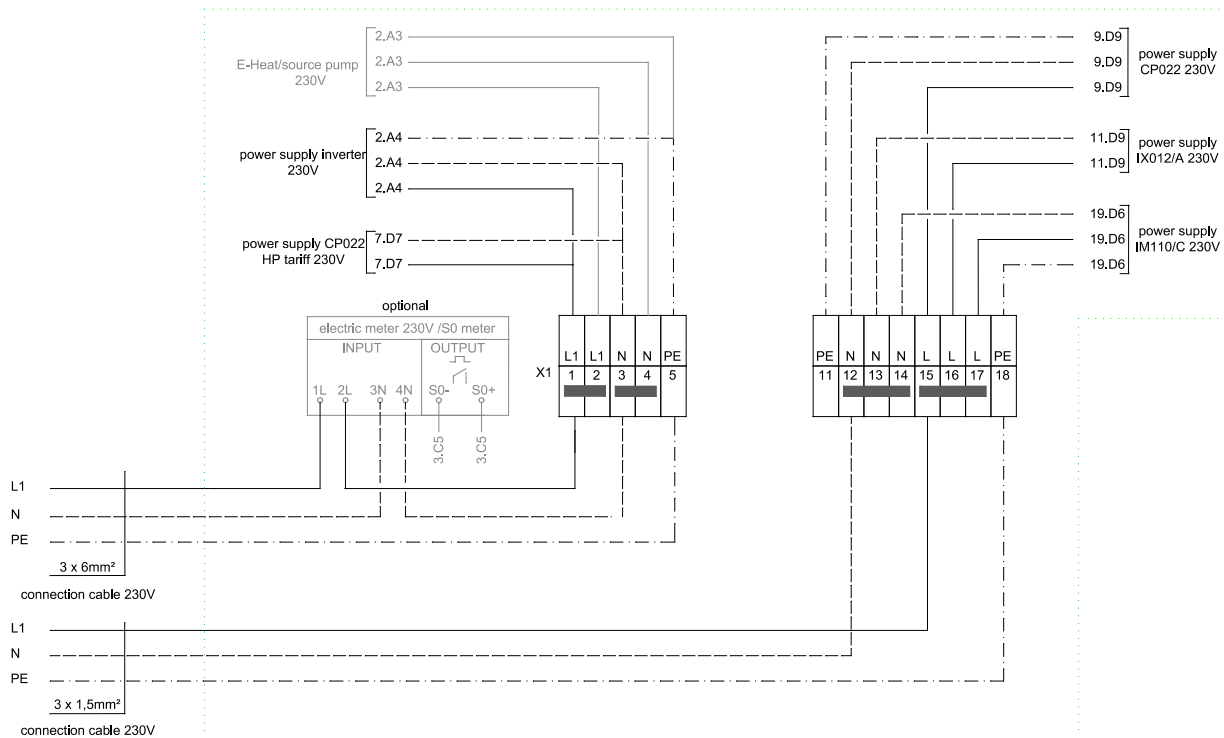

10.4. Wiring diagram of interface

The unit and its interface will not be delivered with all plugs. The connection plugs are included in the different additional parts packages (for example heat pressure switch,...). but can be ordered seperatly at AT-Tec. For more details have a look at the electrical connection diagram for this heat pump type.

IO configuration :
each configuration available

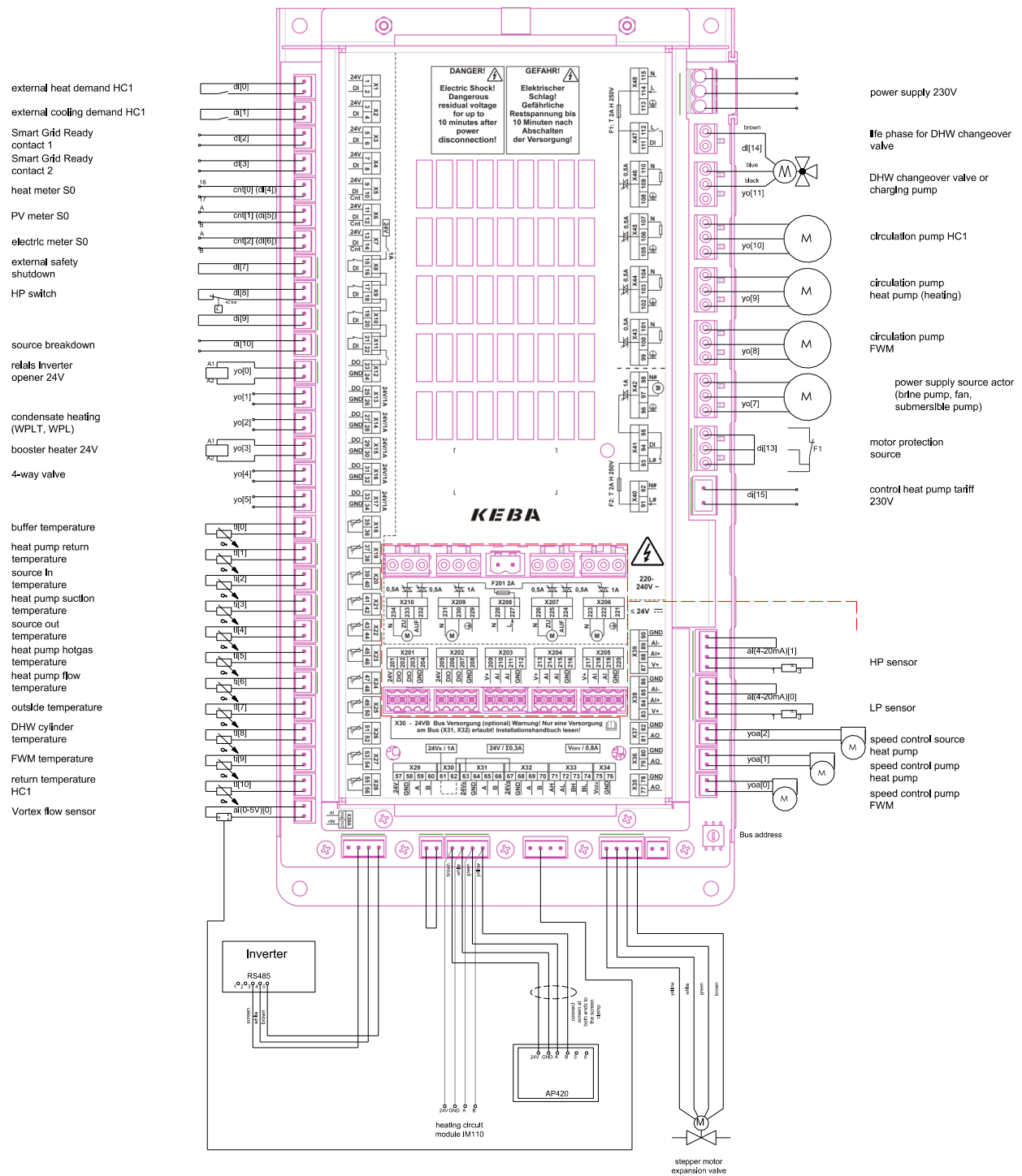

10.5. Wiring diagram of extension Z201

IO configuration:

1 HKgem_1 HKd_Kühlen

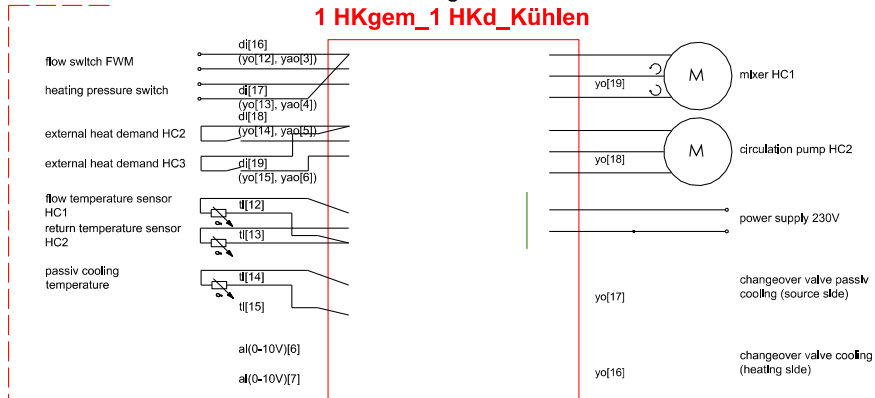

IO configuration:

1 HKgem_ZIRK_Kühlen

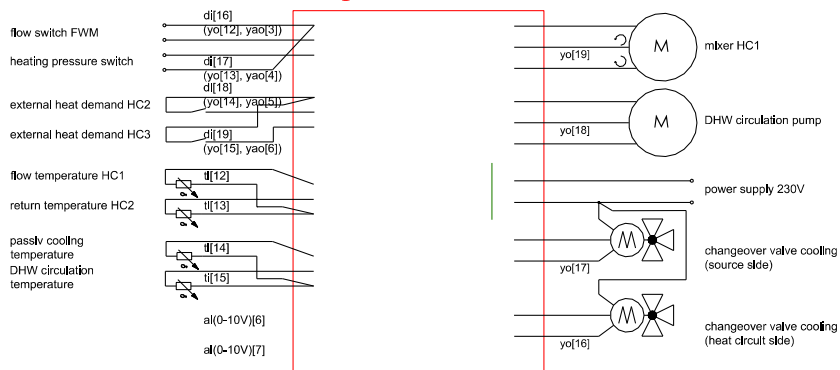

IO configuration:

2 HKgem_1HKd

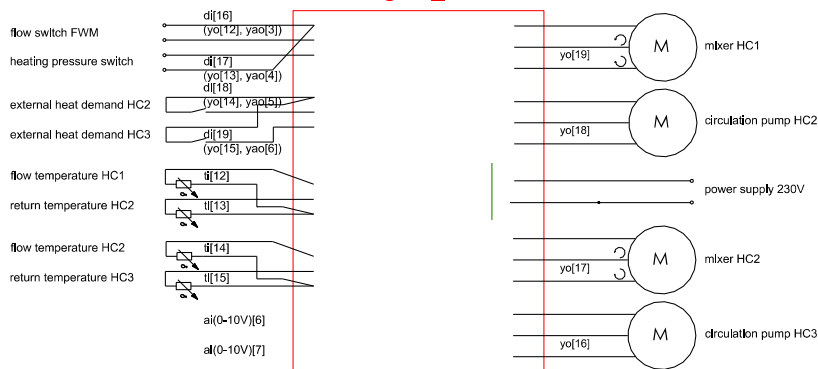

IO configuration:

2 HKgem_ZIRK

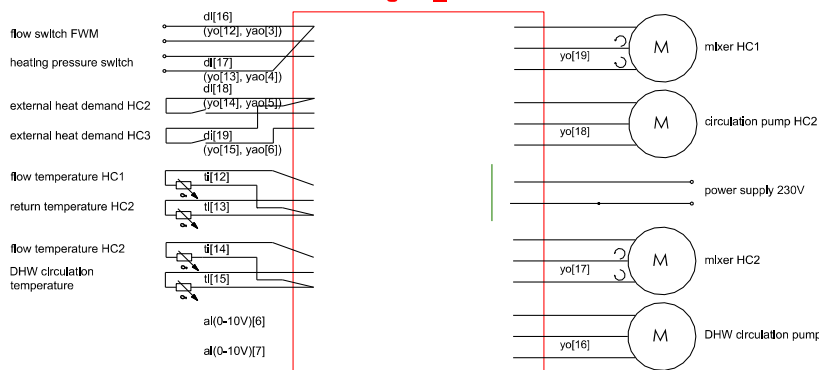



IO configuration:
4 HKgem_1 HKd_2Solar

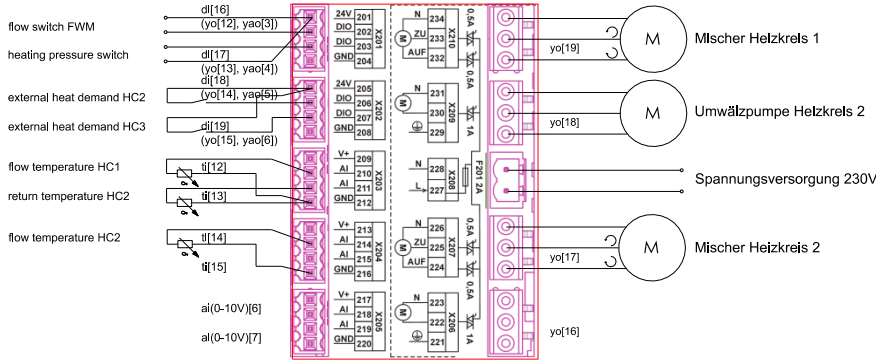

IO configuration:
4 HKgem_1 HKd_Zirk_2Solar

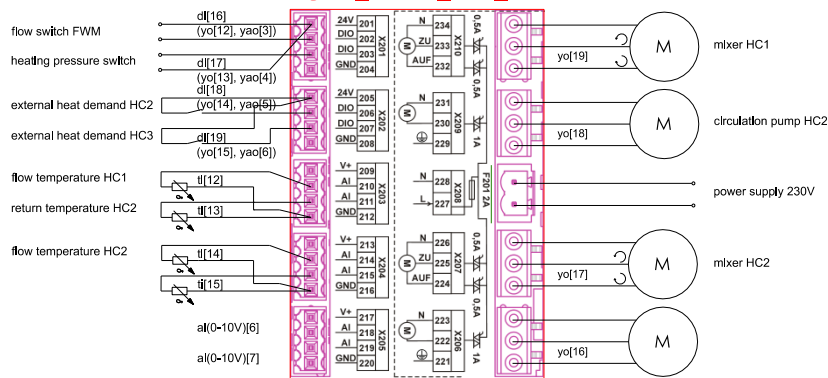

IO configuration:
3 HKgem_1 HKd_Kue_2Solar

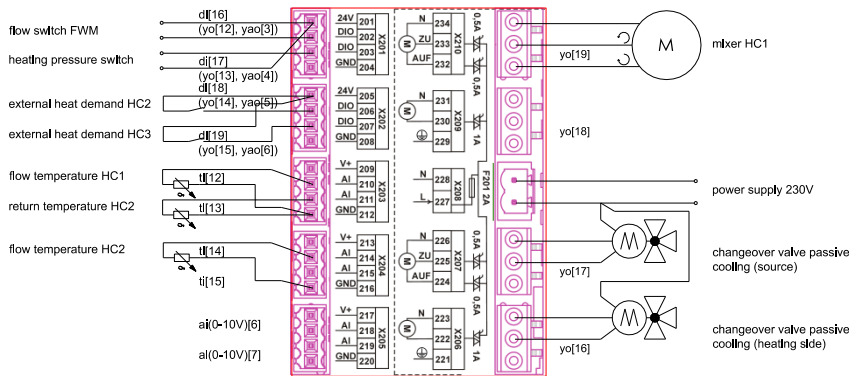

IO configuration:
3 HKgem_1 HKd_ZIRK_Kue_2Solar

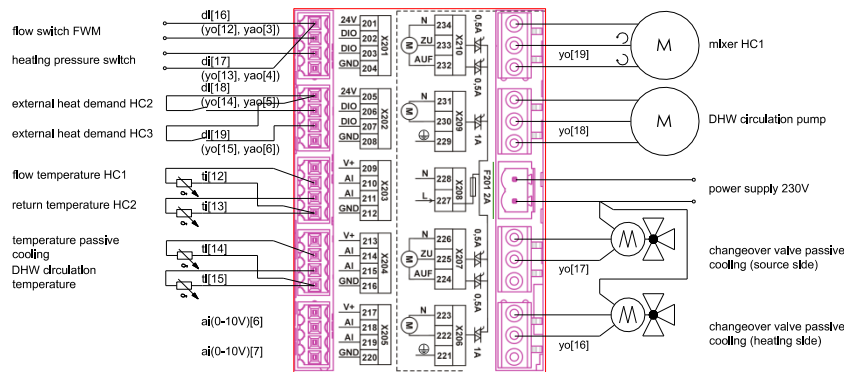

1.1. Wiring diagram of heating circuit module IM110

4HKgm_1HKd_2Solar

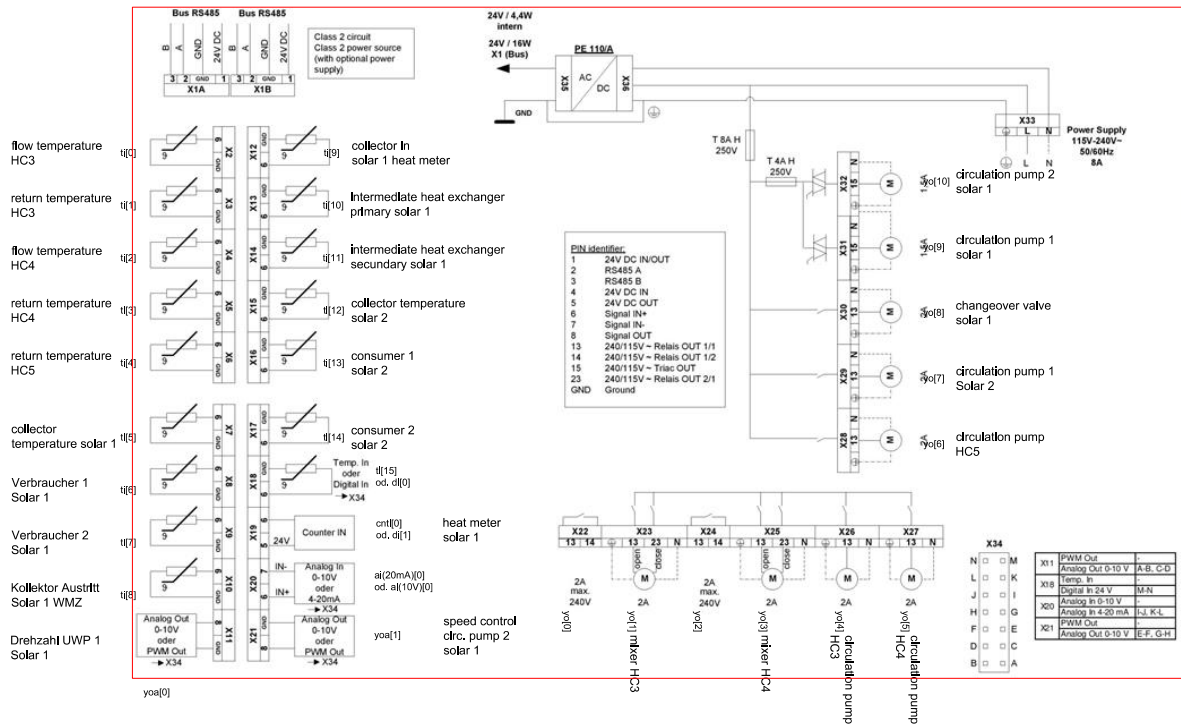

4HKgm_1HKd_ZIRK_2Solar

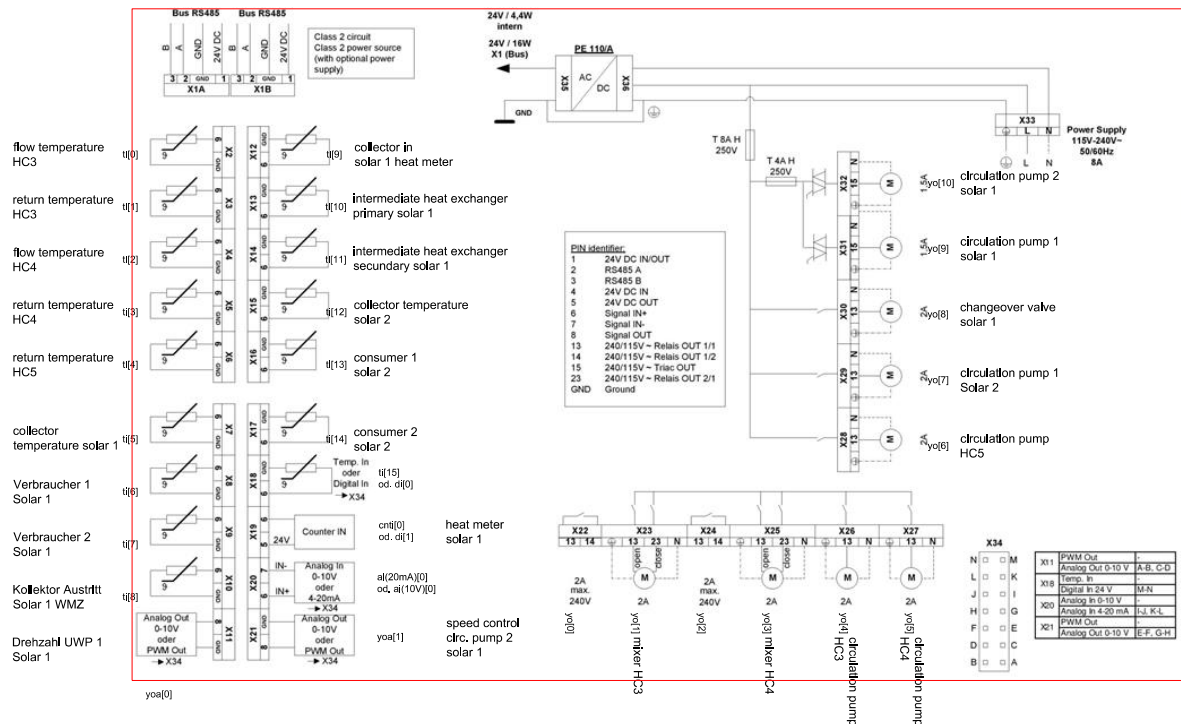

3HKgm_1HKd_Kue_2Solar

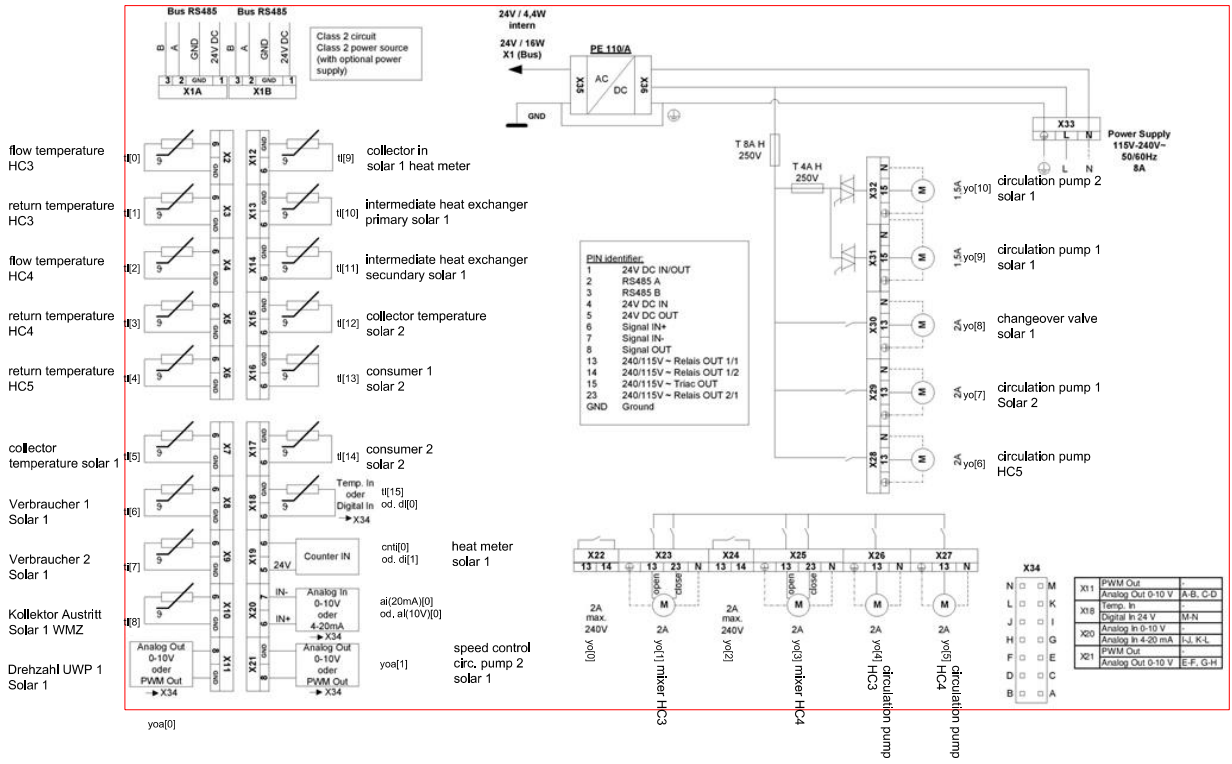

3HKgm_1HKd_ZIRK_Kue_2Solar

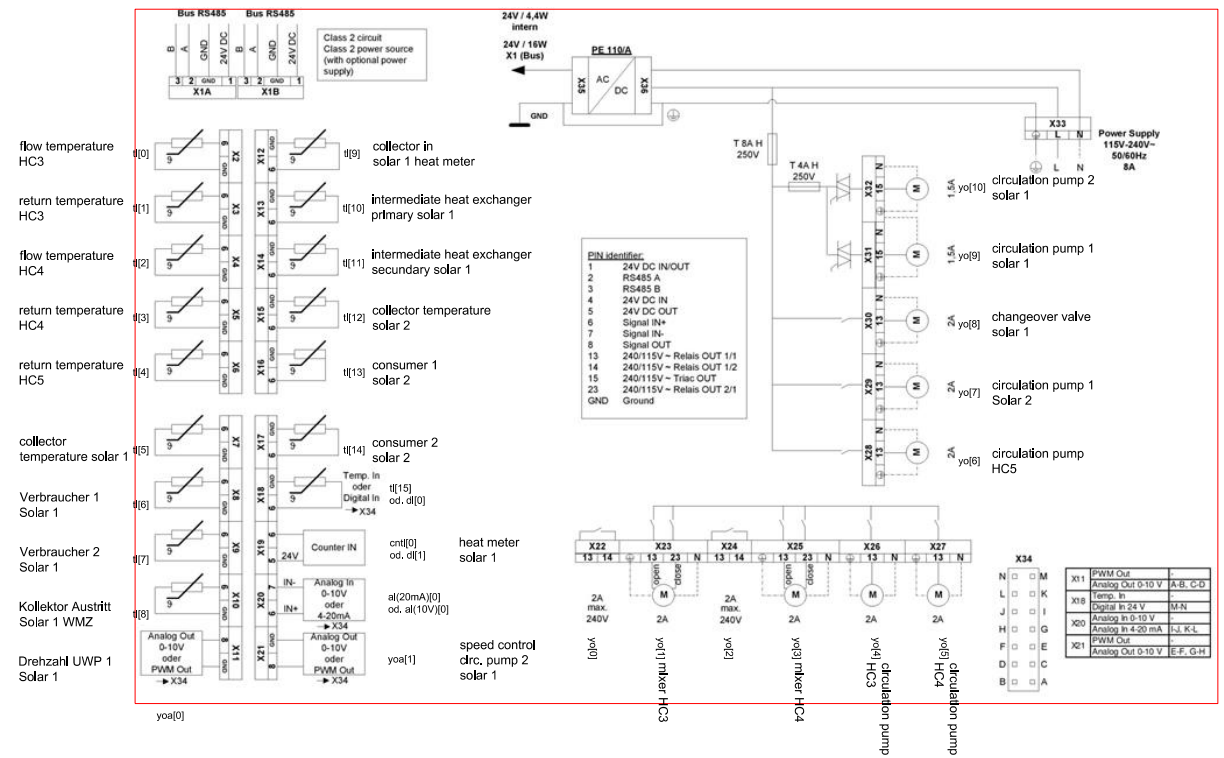

10.6. Connection of the Controller AP420 for wall mounting

Description of the assembly

The NTouch is designed for operating and display tasks and intended for operation in closed rooms.

A BUS cable is used for the power supply and communication with other components of the control system. The NTouch is equipped with a TFT colour display with resistive touch sensitivity and has the following interfaces:

- 1 Ethernet interface
- 2 USB interfaces
- 1 system BUS interface incl. supply



- 1 ... Fixing holes for wall mounting or installation on a flush-mounted box
- 2 ... Ventilation louvres
- 3 ... Cut-out as cable entry

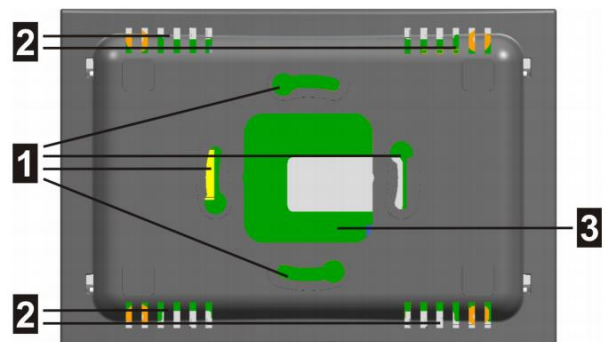

- 1 ... Screened connection for system BUS
- 2 ... System BUS interface
- 3 ... Type plate
- 4 ... Battery
- 5 ... Ethernet interface
- 6 ... USB 0 (accessible from outside)
- 7 ... USB 1

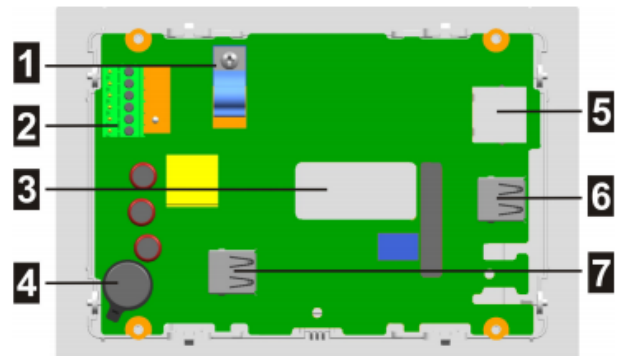

The installation surface must have an unevenness of ≤ 0.5 mm. This level must be assured during operation, installation and storage. To install the assembly, proceed as follows:

Open the NTouch casing by pressing lightly with a thin object on the bottom of the device, as shown in the figure below. Push the top of the housing up and remove.

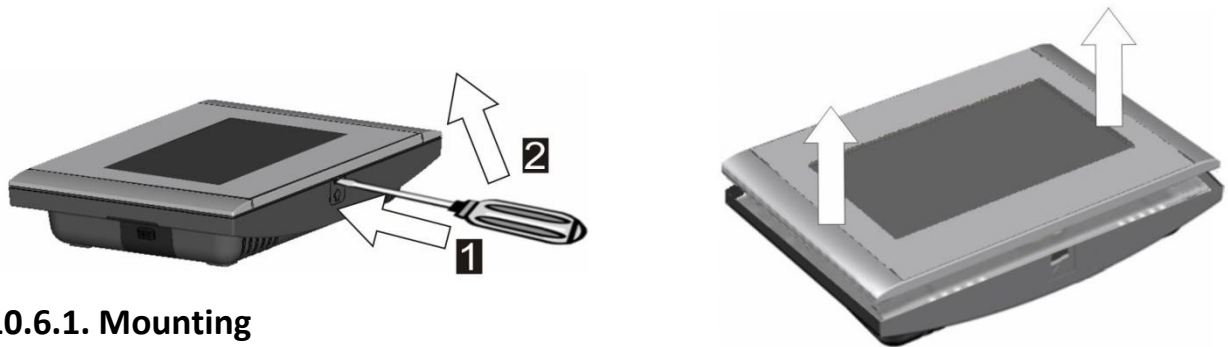

10.6.1. Mounting

Space requirements

Above and below the device: at least 30 mm.

The ventilation louvres must be kept completely clear.

The device should not be installed close to heat sources (e.g. radiators) or in areas with a strong draught (e.g. close to doors), because otherwise, the captured room temperature may be distorted. The NTouch is suitable for mounting on a flush-mounted box (diameter 60 mm) and for horizontal wall mounting on a level, appropriately load-bearing and fire resistant substrate (e.g. a brick or concrete wall).

In the case of installation above a flush-mounted box, the electrical cables routed into the box must first be protected against draughts. Otherwise, cold air may be drawn in through the cables and may reach the room temperature sensor inside the device, which may result in the measuring result being distorted by several degrees Celsius.

Proceed as follows:

1. Mark out the holes at the relevant points on the wall.
2. Drill holes for screws with a 3 mm diameter.
3. Insert rawl plugs into the holes.
4. Open the NTouch casing by pressing lightly with a thin object on the bottom of the device, as shown in Figure 4: Opening the casing. Push the top of the casing up and remove.
5. Route required cables through the cable entry on the back of the casing.
6. Use screws and the fixing holes provided to secure the bottom section of the casing to the wall or on a flush-mounted box. Ensure that the text "Top/Oben" inside the bottom section of the casing is correctly aligned.
7. Once the wiring is complete, refit the top section of the casing on the bottom section and push it down until it clicks into place.

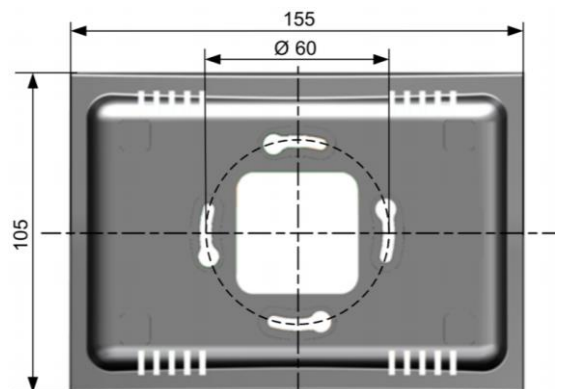

10.6.2. Connections and wiring

- Always route cables/leads of ultra-low safety voltage circuits (e.g. BUS) so that they are safely insulated against hazardous low voltage circuits.
- When using cables/leads of ultra-low safety voltage circuits (e.g. BUS), apply strain relief, because otherwise, they may drop on to dangerous voltages under the programming unit.
- Remove small parts (e.g. bits of cable and copper) from the casing once wiring has been completed.

Strain relief

Replace the BUS cable screen on the screen clamp and apply strain relief by tightening the screw on the screen clamp.

Power supply and BUS connection

The NTouch is supplied with voltage via the system BUS. Connect no other external power supply.

System BUS interface

The BUS interface with the integral 24 V DC supply is located at the top left of the open device.

- 1 ... System BUS interface (pin 1 - 4)
- 2 ... Screen clamp

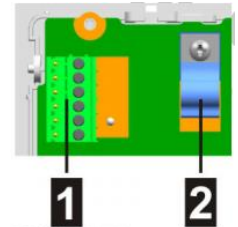

Use a screened cable for the connection. Connect the screen level with the PCB via the screen clamp provided (cable screen pulled back over the cable insulation).

Systembus-Pin assignment

- 6 ... PT1000
- 5 ... eBus
- 4 ... RS-485-B
- 3 ... RS-485-A
- 2 ... GND
- 1 ... 24 V DC

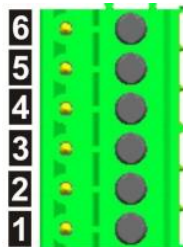

Systembus- cable type

Always use a screened cable (braided screen) with 4 cores.

Recommended BUS cable: YSLCY-OZ 4 x 0.5 mm²

Cable length

Use a screened cable with 4 cores. The total cable length of the system (heat pump, NTouch, TRS14, Heating circuit, ...) is limited to 150m.

Ethernet interface

The Ethernet interface is located at the top right of the open device.

Use a non-crossover cable.

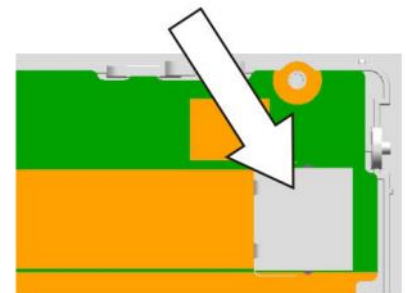

Ethernet-cable type

The screened connection has been tested with the AT-Tec "network cable grey". Use this or an equivalent quality cable for the connection (twisted pair and screened data cables with an impedance of 100 Ω \pm 15%, ...).

Ethernet-cable length

A 100 Mbit/s Ethernet transfer is specified as per IEEE 802.3 up to 100 m (50 m is guaranteed by AT-Tec). In an EMC-disturbed environment, the maximum possible transfer distance may be shorter.

Minimum bending radius:

- during installation: 60 mm
- for an installed cable: 50 mm

USB-Ports

For the connection of external USB devices (USB 2.0 high speed), there are 2 ports available.

Connection of the AP420

Connect the NTouch to the internet and to the heating circuit module or the heat pump. The internet connection is via the Ethernet interface located at the top right of the assembly.

Communication with the heat pump takes place either via the heating circuit module or, in the case of simpler systems without a HCM, via a direct connection.

The following diagram illustrates the connection to the heating circuit module.

Connect the cable (4 x 0.5 mm²) similarly to the supplied 4 x 0.5 mm² cable from the heat pump to terminal X1B in the heating circuit module.

Assignment is as follows:

Connect yellow to 3, green to 2, white to GND and brown to 1 or 24 V. Secure the screen at the screen clamp.

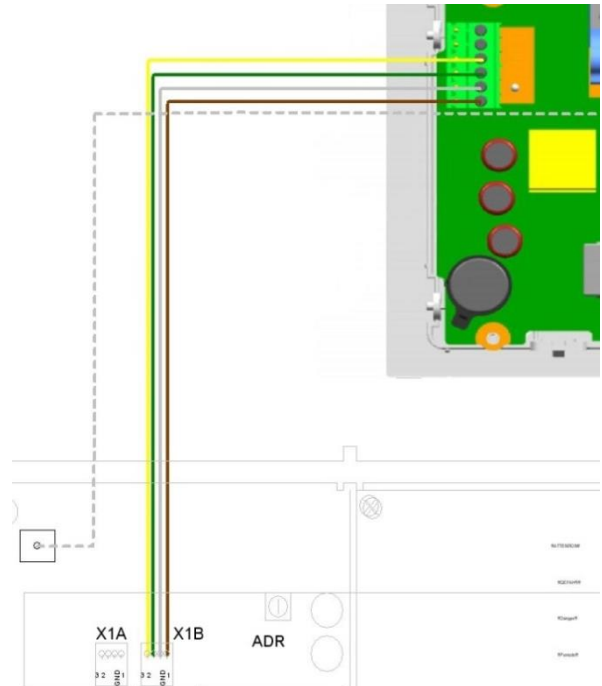

Removing the assembly

When removing the assembly, it is important to ensure and check that it is fully isolated from the power supply. To remove the assembly, proceed as follows:

1. Disconnect the NTouch from the power supply.
2. Open the NTouch casing by pressing lightly with a thin object on the bottom of the device, as shown in Figure 4: Opening the casing. Push the top of the casing up and remove.
3. Disconnect all electrical NTouch connectors.
4. Undo the fixing screws on the bottom section of the casing.
5. Take the bottom section of the casing off the wall.

10.7. Connection of the Controller OI420

Description of the assembly

The digital control unit TRS 14 allows convenient adjustment of the desired room temperature and the mode of heating from the living area.

The settings are adjusted by easy to use buttons and visualised with LED indicators. In addition, the digital controller is used as room thermostat.

The TRS 14 transmits the actual temperature value to the heating control.

The connection with the other system components, as well as the 24 V supply and the data connection are made with a bus cable.



- 1 ... Fixing holes for wall mounting
- 2 ... Fixing holes for mounting on a flush box
- 3 ... Recess for the cable entry
- 4 ... Ventilation louvres

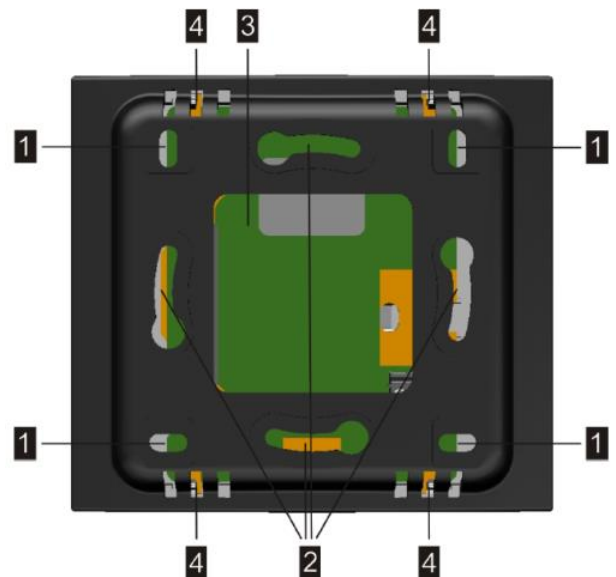

To ensure a sufficient air circulation, the TRS 14 must be installed horizontally on the wall.

Furthermore, the device may not be installed near heat sources (e.g. radiators) or in areas with strong drafts (e.g. near doors) otherwise the room temperature measurement can be corrupted.



When the TRS 14 is installed on a recessed conduit box the electrical hoses previously have to be hedged against drafts. Otherwise cold air can be drawn through the tubes and the measurement result may be falsified by several degrees.

10.7.1. Montage

Space requirements

Above and below the device: at least 30 mm.

The ventilation louvres must be kept completely clear.

The device should not be installed close to heat sources (e.g. radiators) or in areas with a strong draught (e.g. close to doors), because otherwise, the captured room temperature may be distorted. The NTouch is suitable for mounting on a flush-mounted box (diameter 60 mm) and for horizontal wall mounting on a level, appropriately load-bearing and fire resistant substrate (e.g. a brick or concrete wall).

In the case of installation above a flush-mounted box, the electrical cables routed into the box must first be protected against draughts. Otherwise, cold air may be drawn in through the cables and may reach the room temperature sensor inside the device, which may result in the measuring result being distorted by several degrees Celsius.

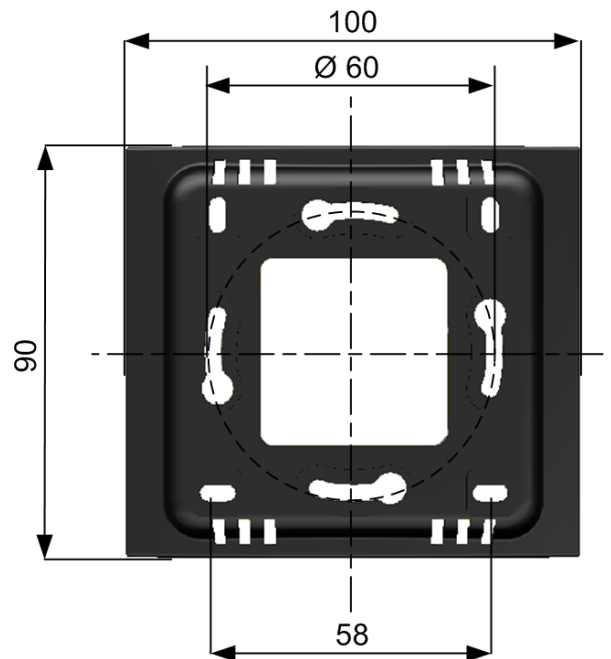

Proceed as follows:

1. Mark the drill holes at the intended location on the wall.
2. Drill holes for screws with 3 mm diameter
3. Put the wall plugs into the holes.
4. Open the TRS 14 casing by pressing lightly with a thin object on the bottom of the device, as shown in the following figure. Push the top of the casing down and remove.
5. Insert required cable through the cable gland on the rear panel.
6. Use screws and the fixing holes provided to secure the bottom section of the casing to the wall or on a flush box. Ensure that the text "Top/Oben" inside the bottom section of the casing is correctly aligned.

10.7.2. Connections and wiring

- Always route cables/leads of ultra-low safety voltage circuits (e.g. BUS) so that they are safely insulated against hazardous low voltage circuits.
- When using cables/leads of ultra-low safety voltage circuits (e.g. BUS), apply strain relief, because otherwise, they may drop on to dangerous voltages under the programming unit.
- Remove small parts (e.g. bits of cable and copper) from the casing once wiring has been completed.

Strain relief

The bus cable must be attached with a cable tie to the device provided for strain relief.

Power supply and BUS connection

The NTouch is supplied with voltage via the system BUS. Connect no other external power supply.

Systembus-interface

This interface device is located in the bottom right corner. For the connection, a shielded cable (4 x 0.5 mm²) has to be used and the shield must be connected to the surface of the circuit board (cable shield back over the cable insulation).

Systembus-Pin assignment

- 4 ... RS-485-B
- 3 ... RS-485-A
- 2 ... GND
- 1 ... 24 V DC

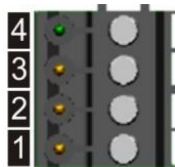

Cabeltyp-systembus

Always use a screened cable (braided screen) with 4 cores.

Recommended BUS cable: YSLCY-OZ 4 x 0.5 mm²

Cable lenght

Use a screened cable with 4 cores. The total cable length of the system (heat pump, NTouch, TRS14, Heating circuit, ...) is limited to 150m.

Connection of the OI420

Power is supplied via the bus system. The bus interface is based on RS485. This interface device is located in the bottom right corner.

The bus cable must be attached with a cable tie to the device provided for strain relief.

For the connection, a shielded cable (4 x 0.5 mm²) has to be used and the shield must be connected to the surface of the circuit board (cable shield back over the cable insulation).

If two or more TRS 14 are to be connected to the heating circuit module they have to be connected in series. That means that the cable of the first TRS 14 has to be looped to the second and continuing.

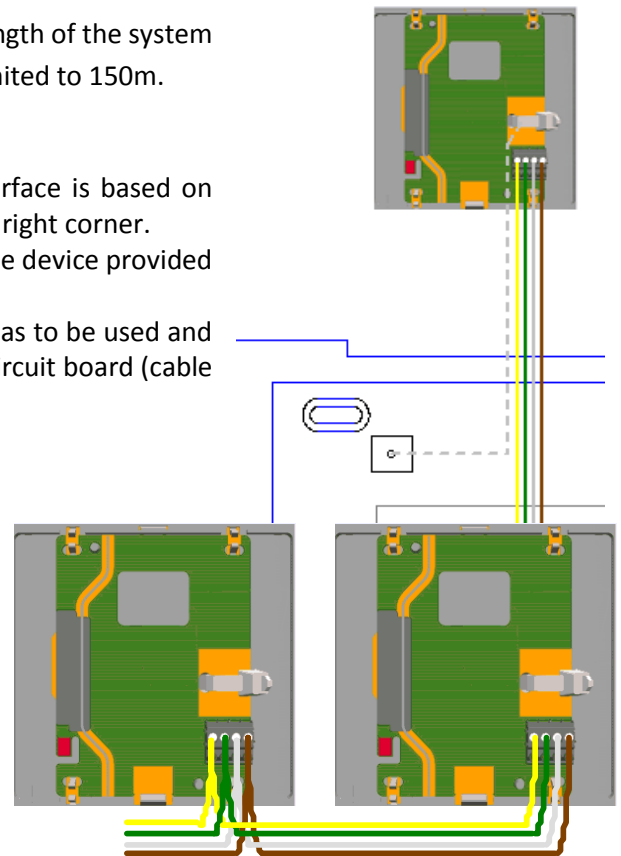



Removing the assembly



When removing the assembly, it is important to ensure and check that it is fully isolated from the power supply. To remove the assembly, proceed as follows:

1. Disconnect the NTouch from the power supply.
2. Open the NTouch casing by pressing lightly with a thin object on the bottom of the device, as shown in Figure 4: Opening the casing. Push the top of the casing up and remove.
3. Disconnect all electrical NTouch connectors.
4. Undo the fixing screws on the bottom section of the casing.
5. Take the bottom section of the casing off the wall.

10.7.3. Assign to heating circuit



To assign the room control device TRS 14 to a particular heating circuit, proceed as follows:

Press the  and  keys at the same time for 5 seconds. The LED of the first operating mode (left LED on the upper arc) lights up and signals the selection of the menu item "bus address".

Now press  and  to adjust the desired address.

The LED-row is used to display the currently selected address value. Starting from the left, the addresses 1 to 5 are displayed.

If for example the LED at -2.5 degrees lights up, the room controller is assigned to the first circuit. If the LED at -2.5 and -2 degrees light up, the controller is assigned to the second heating circuit.

The setting may be changed with the  and  button.



To save the configuration, the arrow keys have to be pressed for 5 seconds again.

If during a time of 30 seconds no settings are made, the controller goes back to the start menu, without saving any settings.

If 2 or more room controllers are assigned to the same heating circuit the status LED on the TRS 14 lights up yellow and red.



10.7.4. Operating

Temporarily changing room temperature



By using  and  you have the option to change the room target temperature (depending on the temperature prescribed by the current time program).

This setting is reset when the time program starts the next time.

Abschalten des Heizkreises

Use button  and  to disable the heating circuit.

Activate automatic operation

Press  and  until the LED at  (automatic mode) lights.

Status LED

- 1 ... Temperature offset
- 2 ... Adjusting the temperature
- 3 ... Changing the operating mode
- 4 ... Standby
- 5 ... Night
- 6 ... Automatic mode
- 7 ... Day
- 8 ... Party



11. Operation and display

This chapter describes the basic screen display and important controls of the display interface.

11.1. User level

Several user levels exist on the visualization, which can be divided in the three "Easy", "Advanced" and "Expert" modes that are intended for certain user groups. Depending on the user level, certain masks are accessible and special information parameters and setting parameters will be displayed. Thereby, they offer different functionality levels. The end customer user can operate the heating system and adjust it to suit individual needs. The service technician user can configure the heating system and start up the system.

Level	Mode	User	Functionalities
1	Easy	End customer	Minimum setting options, no User Password required
2	Advanced	End customer	Additional setting options, User Password "100" required
4	Plumber	Technician	Settings for the heating systems manufacturers . Access to needed parameters. Service technician password required
10	Expert	Technician	Access to all parameters. Service technician password required

11.2. Display and operating elements

Status light



This display element indicates whether a certain parameter/option has been set (status light turns green) or not (status light turns white).

Selection dial



The selection dial can be used to set values (segmented in specified increments) The value displayed in the center is currently selected. Touch the selection dial and move it up or down to select a new value.

Open sub mask



This button indicates that there is a sub mask for the corresponding entry, which can be opened here. It also opens input panels for the individual parameters.

Menü back



With this button you can return to the mask from where you accessed the current mask. Name of the original mask will be displayed to the right of the button.

ON/OFF-switch

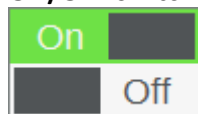

Specific settings and system options can be turned on or off here.

Scrollbar



If more entries for one mask exist than what can be displayed on the screen, you can scroll through the mask (by using the up and down arrows as well as by moving the scrollbar between the arrows). Scrolling through the screen entries is done on a per line basis.

Close/Off/Open slider



This is a sliding button used in conjunction with specific setting parameters to select one of the three states **Close**, **Off** and **Open**.

Text Selection menu

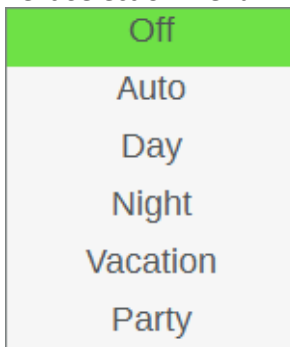

Used to select a status. The number and type of the status texts differ depending on the parameter. After selecting an entry, the selection menu closes automatically and the selected status text appears in the parameter field.

Input field

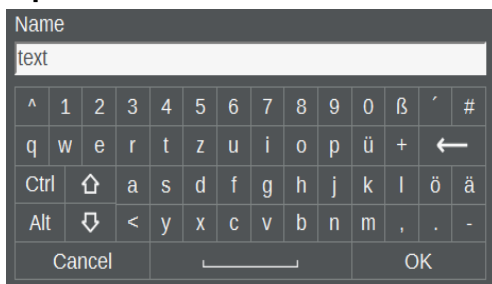

Touching a field automatically opens the keyboard for the respective input field. Text input fields are associated with the alphanumeric input panel. Here, the entered text is displayed on the editing line and after completed confirmation, by pressing **OK**, the value from the editing line is accepted and carried over. Switching to the key layout with additional character is carried out with **ALT**.

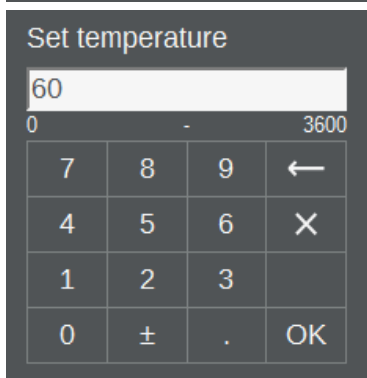

Numeric input fields are associated with the numeric input panel. The value range within which an entry is possible is displayed below the editing line. If a value is entered that falls outside of the displayed range, the value cannot be accepted with **OK** and the value range is highlighted in red.

In general, the title line displays an exact designation of the parameter for which the panel is currently open. Via **X** you can exit an input panel again without accepting the entered values. Inputs on the editing line can be deleted with **←**.

11.3. Visibility

Some masks of the detail menu are only visible when the corresponding modules (heating circuit, hot-water tank, solar circuit, ...) have been activated. Some masks (e.g. **Brightness**) are only accessible via the local visualization.

12. Operating masks - Easy

12.1. Start mask home



The Home mask displays a clearly structured overview of the most important display values and setting options. Among other items, it includes a display of the exterior temperature and pull-up options for the masks. **Short information** and **Operating mode for heating circuit**. A heating circuit can be selected via a selection bar and the nominal temperature can be modified.

Information

The nominal room temperatures of a heating circuit can only be set within a range of 5°C above and below that temperature, which has been set for the respective operating modes in the mask **Operating mode for heating circuit**.

The screenshot shows the Home mask interface with the following elements and callouts:

- 1: Alerts icon (triangle with exclamation mark)
- 2: Time and Date (01:06, 08/09/2016)
- 3: Remote maintenance icon (hand with gear)
- 4: Activity icons (hand, three horizontal lines, wavy line)
- 5: Nominal room temperature adjustment (up/down arrows)
- 6: Heat/Cool request icon (flame/ice)
- 7: Operating mode for heating circuit (power icon)
- 8: Humidity (46%)
- 9: Heating circuit selection (HC1, HC2, HC3)
- 10: Hot water temperature (38.5°)
- 11: Exterior temperature (Out 14.2°)
- 12: Call Mask: Settings (hamburger menu)
- 13: Select heating circuit (HC1, HC2, HC3)
- 14: Additional mask (info icon)

Legend:

- 2 Time and Date
- 3 Display remote maintenance
- 4 Display activity icons
- 5 Change Nominal room temperature
- 6 Display heat/cool request
- 7 Operating mode for heating circuit
- 8 Display humidity
- 9 Nominal room temp. of heating circuit
- 10 Display hot water temperature
- 11 Display exterior temperature
- 12 Call Mask: Settings
- 13 Select heating circuit
- 14 Additional mask

Example: Adjustment of the daytime nominal temperature on the Home mask

If the daytime nominal temperature on the mask **heating circuit** has been set to 22°C, the actually desired daytime temperature can be adjusted directly on the mask **Home** in the range from 17°C to 27°C. This adjustment of the temperature on the mask **Home** does not change the normally set daytime nominal temperature on the mask **heating circuit**.

Alerts

The icon  signalizes on the **Home** mask that some alarms in their respective submask are due. By selecting this icon the mask **Alerts** is opened. The Mask contains detailed information of the alert.

Additional mask

The  icon allows to open an additional mask. If a hot water tank is available, the hot water tank temperature mask will be opened after clicking this icon.

Activity icons

Depending on the radiators operating mode the following activity icons will appear above the nominal room temperature:



Operating mode for heating circuit

In this mask, the existing operating modes of the heating circuits can be selected (and thereby continuously activated). Additional details to the operating modes listed here can be found on main mask **Settings** in Heating circuits [] 43].

Icon	Operating mode	Meaning
	Party	Setting of the point in time for the party end.
	Day	Activation of the operating mode Day (normal temperature):
	Timer	Automatic change between day and night. Based in the preset daily heating times (individually based on the day of the week)
	Night	Activation of the operating mode Night (decrease mode).
	Standby	Turning the currently selected heating circuit on and off. For a deactivated heating circuit, the frost protection function remains active.

12.2. Mask settings

In addition to the selection masks of the different system operating modes and the heating circuit operating types that can also be called up at other locations (such as e.g. timer), additional setting masks of the heat generating system can be selected and subsequently edited. This setting mask will be discussed in detail in the following section.

12.3. Basic layout of the settings menu

- 1 Mask display area
- 2 Call Mask: Help
- 3 Mask selection

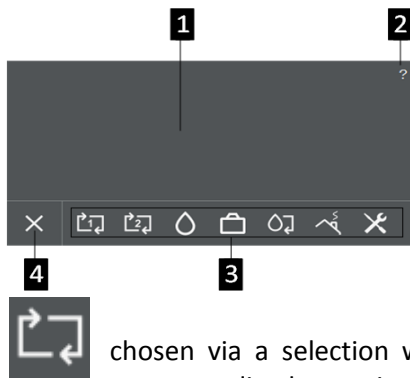

The basic layout is that part of the AT-Tec visualisation, which is always displayed on the screen. It contains the following sub masks:

12.4. Heating circuits

With the selection of a heating circuit a operating mode can be chosen via a selection wheel and then modified. To activate a operating mode press its corresponding button in the menu on the mask **Home**.

Heating circuit operating mode

Description

Heating

HC1	Normal temp.	Reduced temp.
↑	21.5	23.5
	22.0	24.0
Heat	22.5 °C	24.5 °C
	23.0	25.0
↓	23.5	25.5

Enables the setting of the nominal room temperature for the operating mode Day (daytime temperature / normal temperature) and for the operating mode Night (nighttime temperature / lower temperature) as well. The temperatures can be set within the range of 10°C to 30°C. The function of **Cooling** is analog to **Heating**

Cooling

HC1	Normal temp.	Reduced temp.
↑	20.0	19.0
	20.5	19.5
Cool	21.0 °C	20.0 °C
	21.5	20.5
↓	22.0	21.0

The nominal value set here can be adjusted in the mask **Home** within a range of ±5°C.

Party

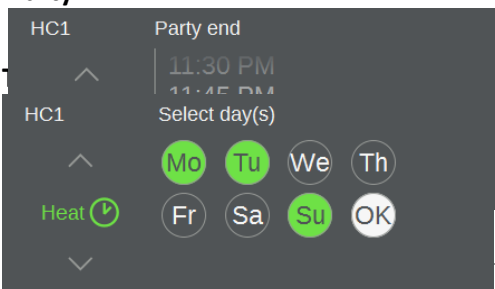

This initiates a one-time adjustment of the daytime temperature heating time (and a potential interruption of the nighttime temperature cycle) without permanently changing the following mask supports the setting of the heating/cooling circuit for each individual day of the week or for a group of days. The "Party End" time is specified through the right selection dial. The weekday selection can be carried out on the initially displayed **Week timer** that time. After that, the heating circuit returns to the original operating mode again. On the **Week timer** individual and consecutive days can be selected via direct touch.

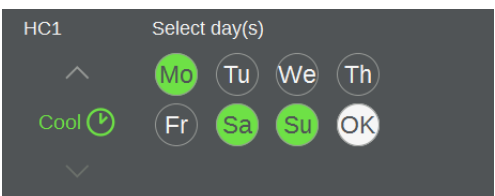

The **Time switch** supports the setting of the nominal hot water temperature for each individual day of the week or for a group of days.

Up to 3 blocks of time can be entered per weekday. The daytime temperature (normal temperature) will be maintained during the active blocks of time and the nighttime temperature (lower temperature) will be maintained during inactive times. The setting of the times takes place via the two selection dials in the middle. Further the time interval of the selection can be set via a selection dial on the right. A block of time can be deactivated by setting the same time for starting time and stop time.

	Start	Stop	Interval
^	16:30	21:00	
	17:00	21:30	15 min
Block 1 ↻	17:30	22:00	30 min
	18:00	22:30	60 min
v	18:30	23:00	

12.5. Hot water

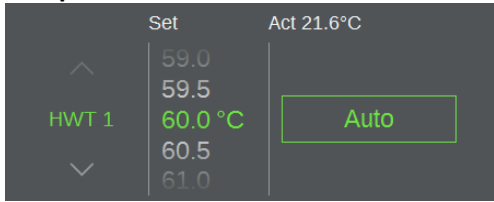
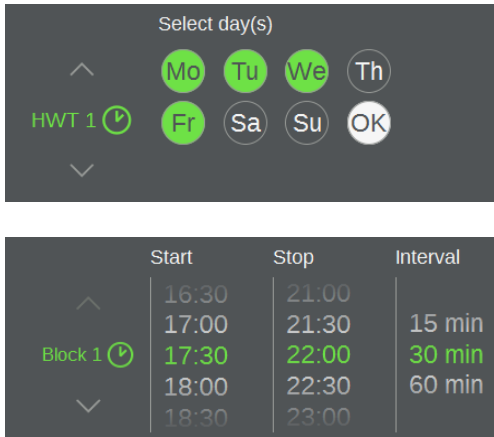

This mask is used to select a hot water tank and offers subsequently settings options to the hot water tank (**Temperature**) and a mask for setting the hot-water tank's week timer (**Time switch**).

Operating mode	Description
<p>Temperature</p> 	<p>This mask shows the actual temperature of the hot water tank. The nominal hot water temperature can be set via selection dial. An toggle field allows to switch between the modes Auto and heating up. Heating up allows the hot-water tank to be heated one single time, which starts immediately unless the current hot water temperature is already higher than the desired nominal temperature. In this case, the heating request for heating the water will not be carried out.</p>
<p>Timer switch</p> 	<p>Its functionality is analog to its functionality for the heating circuits.</p>

12.6. Vacation



Allows the one-time temporary adjustment of the temperature settings for a time span of several days without changing the normally used daytime and nighttime temperatures.

Information

Vacation from 00:00		until 23:59	
Feb 2017	05 We	Feb 2017	20 Th
Mar 2017	06 Th	Mar 2017	21 Fr
Apr 2017	07 Fr	Apr 2017	22 Sa
May 2017	08 Sa	May 2017	23 Su
Jun 2017	09 Su	Jun 2017	24 Mo

► Heat circuit ► Heat circuit ► parameters ► Heating via parameter "Room temp. e can be changed.

Use the selection dials to enter a start date (from) and an end date (to) of the vacation time period. The vacation time frame therefore lasts from 00:00 AM on the start date to 11:59 PM on the end date. During this time frame,

the specified nominal temperature will be maintained and the icon  will be displayed on the **Home** screen. After that, the heating circuit returns back to the original operating mode and uses the saved temperature values.

12.7. Select system operating mode



This mask is utilized to select the system operating mode. The following operating modes can be selected via a selection dial:

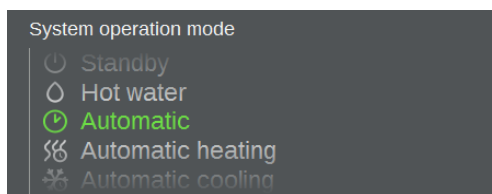

The system operating mode **standby** is set as a default. In this case, the set operating modes of heating circuits, hot-water tank, solar system and photovoltaic are deactivated and the heat generator is not active but the frost protection will remain active.

An active system operating mode must first be selected for the entered settings on the heating circuits to take effect. Available options are the **automatic mode** or the **hot water mode**.

For the **hot water mode** system mode, the heating circuits are turned off (frost protection remains active), hot-water tanks, solar systems and photovoltaic are turned on.

In the **automatic** system mode, heating circuits and cooling circuits, hot-water tanks, solar systems, and photovoltaic frost protection are activated.

From this system mode also the two options **automatic heating** and **automatic cooling** are available, which only have one type of temperature distribution circuits (heating or cooling) and one type of buffer (heating or cooling). These system mode is also activated automatically, in case of performed settings on the option masks of the system. This modified settings will be accepted when switching to an active system operating mode again.

12.8. Chimney Sweeper



This mask is used to start the chimney sweeper mode by pressing the button "start". The

mask will also show the remaining time as well as the corresponding status icon  on the activity bar of the **Home** screen. The chimney sweeper mode is used to measure the pollution emissions.

Information

The mask **external heat source** is only visible in case of activated option "Has emissions" in **Settings ► Device ► Service ► Ext. heat source ► Parameter**.

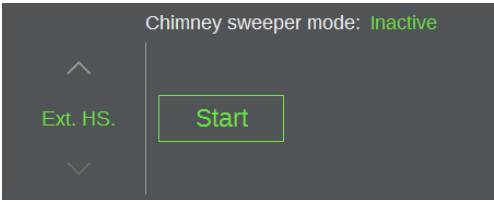
Type of heat source	Description
<p>External heat source</p> 	<p>Upon activation, the actual heat generator is stopped and the external heat source is operated with maximum output, up to 2 hours (see displayed Remaining time). The chimney sweeper function can be terminated by the operator at any time, otherwise the function ends automatically after the indicated remaining time expires. At that time, the system returns to its original operating mode.</p>

12.9. Device

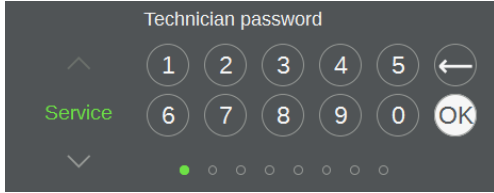
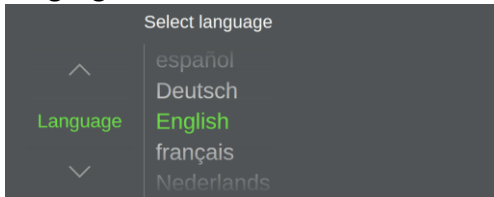
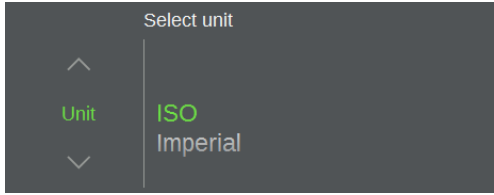

In this mask the following submasks can be chosen via the selecting dial on the left:

Submenu	Description
<p>Service</p> 	<p>By entering (or an incorrect password) you exit the Expert mode again and return to User Level 1. If the Service Technician user level is active and the operating unit is not operated for 30 minutes, the system will automatically reset to the normal user mode (User Level 1).</p>
<p>Language</p> 	<p>This mask allows you to choose the language. The change will occur when leaving this mask.</p>
<p>Unit</p> 	<p>Here you can select the Unit system namely ISO and Imperial in which the device should operate. The change will occur when leaving this mask.</p>

Screen

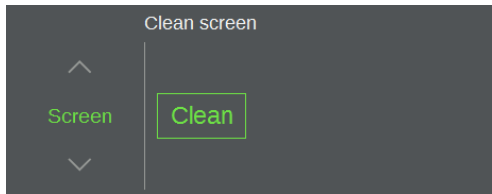

After selecting this parameter, the entry option of the display is blocked for 10 seconds in order to carry out a cleaning of the screen without the touch screen responding to touch.

ATTENTION: Never clean the touch screen with solvents, scrubbing solution or scrubbing sponges. Otherwise the touch screen surface could be damaged!

Use a soft cloth for cleaning which has been lightly moistened with water or with a mild cleaner. The cleaner should always be sprayed directly onto the cloth and not directly onto the surface of the touch screen.

12.10.Mask help



By clicking on the help operating manual opens. to mask. At detail menu parameter is listed description of the mask and its handling is displayed.

- 1 Menu title
- 2 Display area of the masks
- 3 Navigation menu

button, an online window with the The text of the help differs from mask masks the help of each single whereas at all other masks a



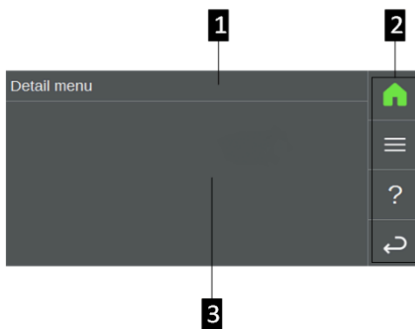

13. Operating masks – Expert

This chapter describes the masks which can be activated by entering a password. Furthermore, additional masks are available in the detail menu. Further masks with display and adjustment parameters of the individual system components are available, which enable the end user to read off most actual values, parameters and options of the system and its individual components.

13.1. Basic layout of the detail menu



The basic layout is that part of the AT-Tec visualisation, which is always displayed on the screen. The Display of the submasks will happen within the Basic layout.

Mask	Description
Home 	Call Mask Home
Detail menu 	Call the first level of the Detail menu .
Help 	Call Mask Help for information concerning the current mask
Menu back 	Revert to previous mask.

13.2. Alarms

Currently pending alarms that were triggered by the control are administrated on the alarm mask with a descriptive title. When an alarm is selected, the detail mask with status, alarm ID, time of occurrence and alarm text of the triggered alarm opens, the two arrow buttons can be used to move up and down

in the alarm table and can be confirmed via button  .

Alarms for which the cause of the error has not been fixed yet will continue to be displayed in the Alarm mask in spite of the confirmation. These alarms will only not be pending any more after the cause of the error has been fixed.

13.3. Time, Date

Contains the basic settings for the display of the user software and the parameters, such as system time and for the illustration on the display, as well as setting the **LED brightness** of the optional remote control.

Date and **Time** are set via their own pop-up windows with selection dials.

The specific **Time zone** can be selected by choosing the region and the related capital city of the respective nation. The settings will finally be accepted by pressing **Apply**. Depending on the selected time zone, summer/winter time is set automatically.

The **Screen saver** activation time (e.g. after 20 min inactivity) can be selected via a text selection menu.

The **Display brightness** as well as the **LED brightness** is set via a numeric input panel, whereat in each case a minimum brightness is given.

13.4. Service

Provision of the functions required for the service, such as e.g. status report, update software, save/load parameters ...

A specially prepared USB stick is required to carry out some of the service functions included herein (e.g. update software, USB data logging, ...), which must be inserted into the operating unit (an USB stick can either be prepared as update stick or as diagnosis stick).

13.5. Save/Load parameters

All setting parameters of the entire control system can be saved locally, on a USB stick or on a terminal device (PC / mobile), or can be loaded from the stick onto the control system.

This mask also provides the expanded options to load parameter templates or to backup one's own new parameter templates. During this process, the setting parameters of individual system components can be saved locally, on a USB stick, or can be loaded from the stick onto the control system.

Load parameters	Save parameters
Load parameters	Save parameters
From storage Local >	To storage Local >
Group System >	Group System >
Name >	Name >
Start loading	Start saving
Detail Menu - Service - Parameters – Load Parameters	Detail Menu - Service - Parameters - Save Parameters

The storage location (locally on the system or onto a plugged-in USB stick) onto which the backup is to be carried out, or from where already existing backup data is to be uploaded, is specified via a text

selection menu. Via web application it is furthermore possible to store the data on the terminal device (PC / mobile).

Parameter "Group" determines what should be stored or loaded: "System"(system parameters), "All LinTabs" or "IO config"

If the parameters are to be saved, the backup file is automatically given a file name with date stamp (e.g. HS-2014-05-03). The name can be changed via the input panel. If the system parameters are to be loaded, the desired parameter set (if existent) can be selected from a text selection menu. In case of loading system options it is switched into **Setup** mode automatically and has to be switched to the desired system operating mode manually.

Load parameter template		Save parameter template	
Load parameter template		Save parameter template	
From storage	Local >	To storage	Local >
Component	Heating circuit >	Component	Heating circuit >
Number	1 >	Number	1 >
Name	>	Name	>
Start loading		Start saving	
Detail Menu - Service - Parameters - Load parameter template		Detail Menu - Service - Parameters - Save parameter template	

Parameter "Component" determines the type of the component that should be stored or loaded. Together with the component type, parameter "Number" determines the specific system module.

Information
It is possible to save two backups of each component in the local memory. If further backups are stored in the local memory, the oldest backups are deleted automatically.

Conventions for "Saving parameters templates":

- Filename for system parameters starts with HS (Heating System)
- Filename for templates starts with LT or IO (linearization tables, IO configurations)
- Filename for components starts with HP, HC (heat pump, heating circuit)

By operating **Start saving** or **Start loading** the backup process or loading process is started and the status is shown on a progress bar. In web application, **Upload** with a standard dialog **Open file** is available, instead of **Start loading** and parameter **Name**.

13.6. Network

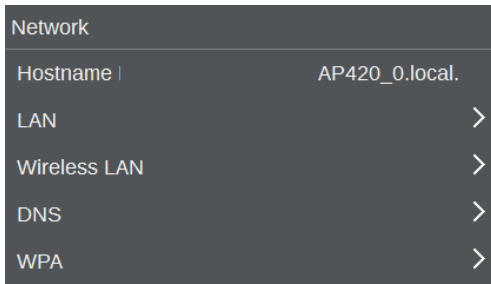

This is not available in the web application and provides settings for the network configuration of **LAN** and **Wireless LAN**. Furthermore masks are provided for entering **DNS** and **WPA**. By selecting a category, special configuration masks are opened where the settings can be carried out.

The "Hostname" displays the name of the master operating unit of the heat generating system.

LAN

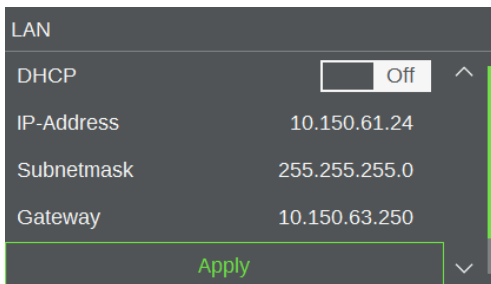

In this mask, the LAN network settings can be edited. The network address can either be:

obtained via DHCP (this enables the automatic integration into an existing network without manual configuration) or specially defined. During this process, the network addresses must be entered manually via input panel.

Designation	Meaning
DHCP	Through the activation of "DHCP", the IP address will be automatically obtained via a DHCP server and the remaining input lines will be deactivated.
IP Address	Indication of the IP address for the visualization communication, as well as
Subnet mask	- the corresponding subnet mask and
Gateway	- the standard gateway

The settings will finally be accepted by pressing **APPLY**.

Below of **APPLY** the "MAC address" of the LAN interface is displayed (necessary for possible IT unlocks).

Wireless LAN

This mask offers the possibility to connect the master operating unit with an existing WLAN network. Like on the mask **LAN**, for this purpose the operating unit requests either an IP address from the DHCP server, or it can be set a fixed IP address on the operating unit.

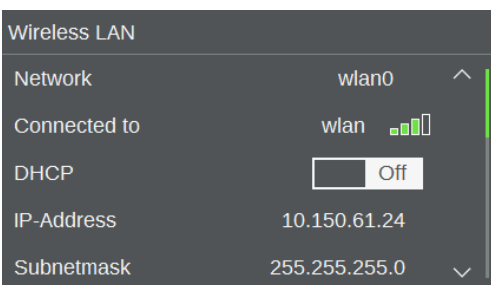

The mask is only fully, when a WLAN stick is connected to the master operating unit and it is also connected to the network that has been defined on the mask **WPA**.

In case of successful connection, the parameter **Connected to** indicates, next to the name of this network, the signal strength of the connection.

The settings will finally be accepted by pressing **APPLY**.

Below of **APPLY** the "MAC address" of the LAN interface is displayed (necessary for possible IT unlocks).

DNS

The IP addresses of up to two DNS (Domain Name System) server (both LAN and WLAN) can be set on this mask. The performed settings will be accepted by pressing **APPLY**.

WPA

In this mask a WLAN connection can be established by inserting the network name (SSID) and also the password (PSK). The performed settings will be accepted by pressing **APPLY**.

13.7. Remote maintenance

Remote maintenance	
Active	<input type="checkbox"/> Off
Internet available	<input checked="" type="checkbox"/>
Connected to server	<input type="checkbox"/>
Device name	name10 >
Password	***** >

With this, remote maintenance via a VPN connection can be activated via ON/OFF switch. Thereby a temporary remote access onto the heating system by a AT-Tec application technician for the purposes of optimization, fault analysis or troubleshooting is enabled.

When opening the mask, the current status of the remote maintenance is automatically determined and displayed. For that purpose via status light is displayed if an Internet connection is available and if a connection to the VPN server (a so-called VPN tunnel) has been established or not. To finish the configuration of the mask **Remote maintenance** the **Device name** and the **Password** of the device, which are defined in the (Remote maintenance) VPN server, must be entered via alphanumeric panels.

Information

An existing connection is required for the Remote maintenance!

- "Internet available" means that the Internet is in principle available but not mandatory that a VPN tunnel can be established.
- Only when "Connected to server" is enabled all settings are valid, and the remote control is functional.

13.8. Restart

Selecting this parameter initiates a restart. After confirming the appearing message window the restart is performed.

13.9. Data logging

Data logging	
Format	Kemro.Scope >
From	08/13/2016 >
To	08/16/2016 >
Download	

Mask is only accessible in the web application.

The recorded system data can be downloaded and saved on the PC. For this purpose, the desired data format must be set via "Format" and the desired period via "From" and "To". Afterwards the recorded data can be transmitted to the PC via **Download**. During transmission of the logged data the system should not be switched off!

13.10.USB Data logging

System data be recorded continuously.

Information

As mentioned at the beginning, the USB stick prepared as diagnosis stick is required.

The data logging can be started/stopped via the ON/OFF switch. The current status of the data logger is displayed.

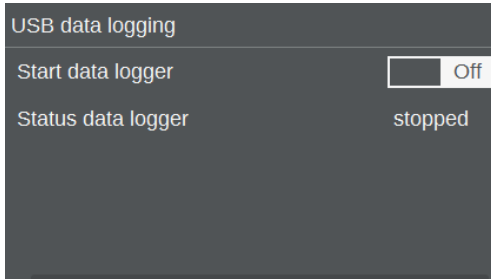

13.11. Status report

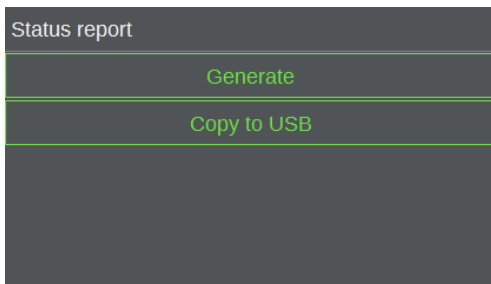

In case of a problem with the system or upon instruction by the service technician, the system condition can be saved in a status report via the button **Generate** and transmitted to an USB stick or a PC for further analysis. During the generation of the status report, an activity bar is displayed. During that time, the system should not be turned off.

After the generation, the status report needs to be transferred to a plugged-in USB stick. Via **Copy to USB** all existing reports will be copied.

Information

In the web application of the visualization **Copy to USB** is replaced with **Download** and the last generated status report is transferred to the PC.

13.12. Diagnostics

Mask is only available in the web application and gives the service technician access to:

- **Event log**
Gives access to a detailed list of recent events.
- **Variable monitor**
Offers an overview of the variables and enables further modification.

13.13.Event log

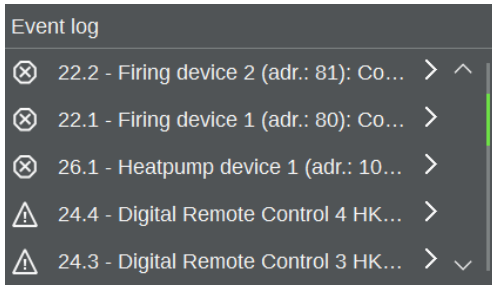

Opens the event log mask which shows the content of the event log in list form. All system alarms are recorded over a longer period of time. Thus offers a complete recording of the system alarm history.

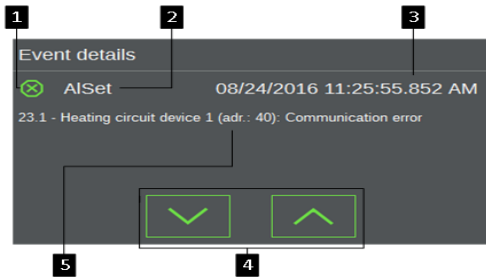

By selecting an event, the detail mask with message ID, time of the occurrence and event text of the triggered event is opened.

- 1 Status icon
- 2 Event class (AIReset, AISet, WebHMI)
- 3 Time the event occurred up to ms
- 4 Moving up and down on the event table
- 5 Event text with message ID

Icon	Event class	Description
	Error	Error and down-time in application/control of the system, which prevent the flawless operation of the system.
	Warning	Warnings of the application. The additional operation of the system (sometimes with limitations) is given.
	Information	Information of the application (to be adhered to!). The complete further operation of the system is given.

13.14.Notification

To use the functions of this mask, **Remote maintenance** must be active (existing internet connection required).

The type of the transmission of the message is set via "**modus**".

"**Recipient**" specifies the receiver of the notification.

"**Language**" determines in which language the messages will be sent. English will be used as the default language, if the message to be sent is not available in the target language on the system.

"**Level**" defines a filter for the Notifications.

To check the correctness of the entered data, a test message can be sent to the given receiver via **Test message**.

Information

Alarms have to queue up a certain amount of time before a notification is sent. The pending alarms are sent, collected in a package.

13.15. System information

Provides general information for the visualization and control system.

13.16. Software update

Software update	
Actual:	KeEnergy.Complete_1.17
New:	nothing found
Start update	

Mask is not available in the web application.

With this mask, a new software version can be uploaded onto the system via USB stick.

Information

The USB stick prepared as update stick is required.

It is recommended to save all parameter of the system before updating the software

In addition to the current software version, a potentially new version is displayed, in case one has been found.

Information

Wait 30 seconds after inserting a USB stick so that the data medium can be recognized by the system.

In order to then carry out the update of the software, proceed as follows:

- 1) Switch the system operating mode to Standby..
- 2) Plug the USB stick into the operating unit.
- 3) Save the parameters (see Save/Load parameters).
- 4) Restart the system or select **Start update** on mask **Software update** to start the update. This may take several minutes.
- 5) During the subsequent start up all I/O devices are updated if necessary.

Finally, the system starts and the updated visualization software will be displayed. Now it is allowed to remove the USB stick that was used for the update.





13.17. Factory settings

Is not available in the web application.

This sets all parameters and system settings, but no operational data, back to the original state at the time of delivery (module type and quantity [e.g. two heating circuits] and parameters to default settings). Following the confirmation of the opening dialog box, all factory settings will be loaded. When resetting the factory settings with User Level 3 also the operational data (e.g. system statistics) are deleted. After setting to factory settings, a new setting-up of system must be performed.

13.18.Charts

The visualization can display up to three different charts. Line charts represent data from the data logger whereas bar charts visualize statistical data.

Designation	Meaning
	Previous Interval , e.g. in the yearly view the previous year will be shown
	Next Interval , e.g. in the yearly view the next year will be shown
	Zoom in , e.g. from the yearly view will be changed to the monthly view
	Zoom out , e.g. from the monthly view will be changed to the yearly view

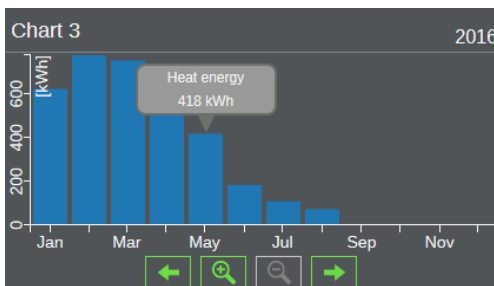

A bar chart supports:

- zoom levels for a year (12 months)
- a month (4-5 calendar weeks)
- 512 MB flash a week (7 days)

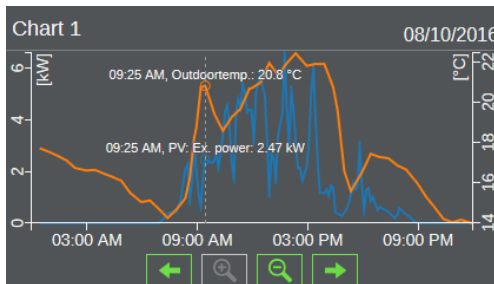

A line chart supports:

- zoom levels for a year (12 months)
- a month (4-5 calendar weeks)
- a week (7 days)
- a day (24 hours)

When the chart area gets clicked, a tip regarding the respective values of the single data sources will be shown.

Chart configuration

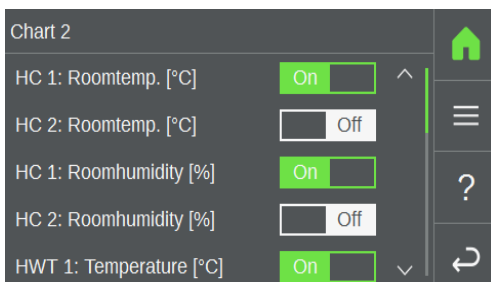

The configuration mask lists all available data sources which can be added to the chart by activating it via the slider. Each chart can contain up to five data sources with two different units. All further data sources will be removed. If a data source from one kind is selected, all data sources from the other kind will be removed from the mask. By pressing the "Save" button, the selected configuration is saved.

14. System schemes

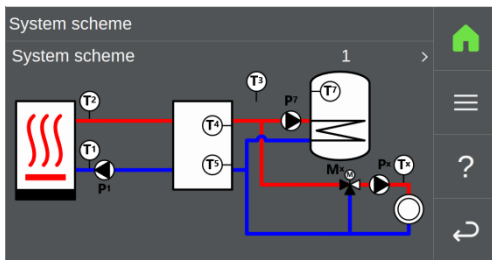

It is possible to choose between different hydraulic schemata, which reflect a certain structure of the system with a different configuration of the function units (system modules). The respective function volume is set by the appropriate options (e.g. reflux lift, unmixed heating circuit, ...).

Solar systems are not shown, but it can be selected, which heating target is associated with it (buffer tank, hot water tank, generic heating target such as swimming pool).

External heat sources are optionally available and are hydraulically similar to the connected heat generator. They have an autonomous (external) controlled circulation pump.

The selection of a schema takes place by confirming the line System scheme and entering the number of the desired schema.

shortcuts	Definition of terms
FU	Function unit
N/A	Not available
T1	Flow temperature of heat generator
T2	Reflux temperature of heat generator
T3	Exterior temperature
T4	Heat buffer temperature top
T5	Heat buffer temperature bottom
T7	Hot water temperature tank x
T8	Cold buffer temperature top
T9	Cold buffer temperature bottom
T10	Collective flow tank for cascades
Tx	Temperature flow of heating/cooling circuit x

shortcuts	Definition of terms
P1	Pump heat generator
P7	Loading pump of hot water tank x
Px	Pump of heating/cooling circuit x
M1	Mixer reflux lift (optional)
Mx	Mixer hot water tank x
V1	Switch valve buffer / hot water tank
V2	Switch valve heating / cooling
Vx	Switch valve heating / cooling of heating/cooling circuit x
V4	Switch valve Buffer / heating circuit

14.1. General system schema

System schema 0

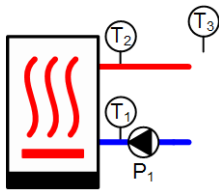

Consists only of the module heat generator (maximum of 4) and optionally an external heat source and external heat request. Without additional optional modules.

Module	min. number	max. number
Heat generator	0	4
Buffer	0	0
Heating circuit	0	0
Hot water tank	0	0
Solar circuit	0	0
Ext. heat source	0	1
Ext. heat request	0	1

System schema 1

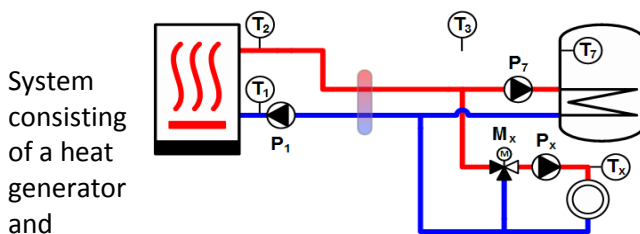
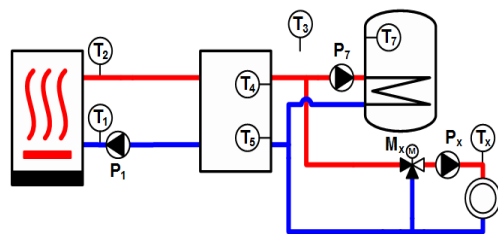

System consisting of a heat generator and optionally an external heat source, external heat request, buffer tank, heating circuits and hot water tanks. The external heat request requests the buffer tank. When the number of heat generators of the system is 0, the heating is carried out via an external heat generator.

Module	min. number	max. number
Heat generator	0	4
Buffer	1	1
Heating circuit	0	8
Hot water tank	0	4
Solar circuit	0	4
Ext. heat source	0	1
Ext. heat request	0	1

System schema 2

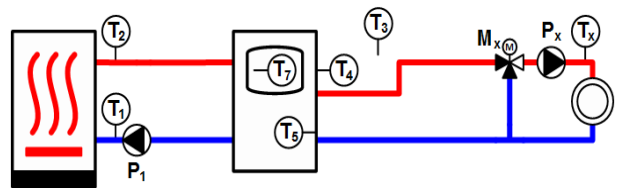

Buffer must be present. Buffer with integrated hot-water tank. Other modules optional. When the number of heat generators of the system is 0, the heating is carried out via an external heat generator. This scheme can also be used for a buffer tank with fresh water module.

Module	min. number	max. number
Heat generator	0	4
Buffer	1	1
Heating circuit	0	8
Hot water tank	0	4
Solar circuit	0	4
Ext. heat source	0	1
Ext. heat request	0	1

System schema 3

Without buffer. A hydraulic separator exists. Other modules optional. When the number of heat generators of the system is 0, the heating is carried out via an external heat generator.

Module	min. number	max. number
Heat generator	0	4
Buffer	0	0
Heating circuit	0	8
Hot water tank	0	4

Module	min. number	max. number
Solar circuit	0	4
Ext. heat source	0	1
Ext. heat request	0	1

System schema 4

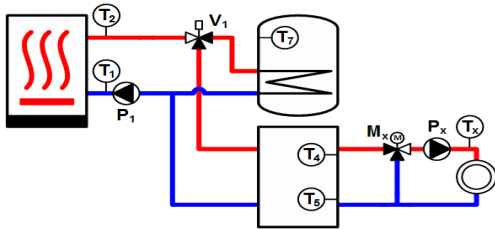

Buffer and hot-water tank must be present. This scheme can also be used for a buffer tank with fresh water module when a zone change is available via a valve. Other modules optional. When the number of heat generators of the system is 0, the heating is carried out via an external heat generator.

Module	min. number	max. number
Heat generator	0	4
Buffer	1	1
Heating circuit	0	8
Hot water tank	0	1
Solar circuit	0	4
Ext. heat source	0	1
Ext. heat request	0	1

System schema 5

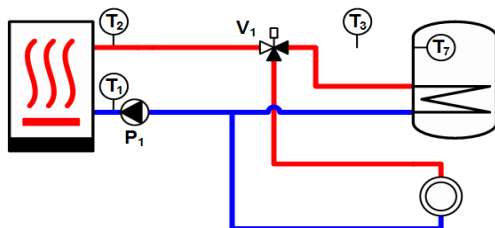

Heat generator and optionally an external heat source, external heat request, an unmixed

14.2. Extended system schema

System schema 6

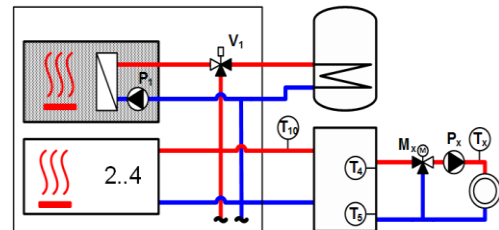

Heat pump cascade and a hot water tank. Optionally with an external heat request and an external heat source. The buffer tank with optional heating circuits is loaded from a collective flow. On a dedicated heat pump a switch valve of the hot water tank is connected.

Module	min. number	max. number
Heat generator	2	4
Buffer	0	2
Heating circuit	0	8
Hot water tank	0	1
Solar circuit	0	4
Ext. heat source	0	1
Ext. heat request	0	1

heating circuit and optionally a hot water tank connected via switching valve.

System schema 7

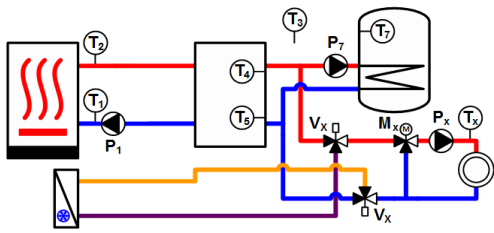

Each circuit has its own switching valve for selection of a heat/cold generator. One

Module	min. number	max. number
Heat generator	0	4
Buffer	1	1
Heating circuit / Cooling circuit	0	8
Hot water tank	0	4
Solar circuit	0	4
Ext. heat source	0	1
Ext. heat request	0	1

System schema 8

The heat buffer is loaded during heating, the cooling buffer during cooling. Each circuit has its own switching valve for the selection of heat/cold tank. It could have one for all. The external heat request requests from buffer.

Module	min. number	max. number
Heat generator / Cold generator	0	4
Buffer	2	2
Heating circuit / Cooling circuit	0	8
Hot water tank	0	4
Solar circuit	0	4
Ext. heat source	0	1
Ext. heat request	0	1

collective switching valve for all circuits. The external heat request requests from buffer.

Module	min. number	max. number
Heat generator	0	4
Buffer	1	1
Heating circuit / Cooling circuit	0	8
Hot water tank	0	4
Solar circuit	0	4
Ext. heat source	0	1
Ext. heat request	0	1

System schema 9

Heat generator and buffer tank with an integrated hot water tank and optionally an external heat source. Each circuit has its own switching valve. It could also have one for all. This scheme can also be used for a buffer tank with fresh water module. The external heat request requests from buffer tank.

Module	min. number	max. number
Heat generator	0	4
Buffer	1	1
Heating circuit / Cooling circuit	0	8
Hot water tank	1	1

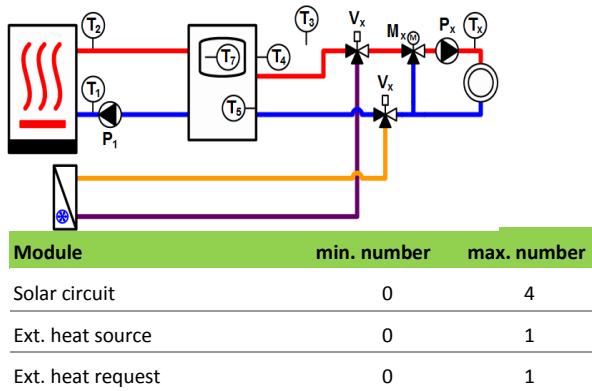

System schema 10

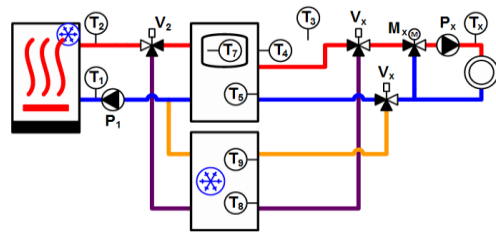

Heat/cooling source, buffer tank with integrated hot water tank, cold buffer tank and optionally an external heat source, external heat request, switching valve for buffer and heating/cooling circuits. In heating mode, the heat buffer is loaded in the cooling mode, the cooling buffer. Each circuit has its own switching valve. It could also have one collective switching valve for all circuits. This scheme can also be used for a buffer tank with fresh water module. The external heat request requests from the heat buffer tank.

Module	min. number	max. number
Heat generator / Cold generator	0	4
Buffer	2	2
Heating circuit / Cooling circuit	0	8
Hot water tank	0	1
Solar circuit	0	4
Ext. heat source	0	1
Ext. heat request	0	1

System schema 11

Heat generator and optionally an external heat source, external heat request, hot water tanks and heating/cooling circuits. The individual circuits and hot water tanks are connected via a hydraulic separator. Each load must have its own circulation/charge pump. Each circuit has its own switching valve. It could also have one

for all. The external heat request requests from the heat generator.

Module	min. number	max. number
Heat generator	0	4
Buffer	0	0
Heating circuit / Cooling circuit	0	8
Hot water tank	0	4

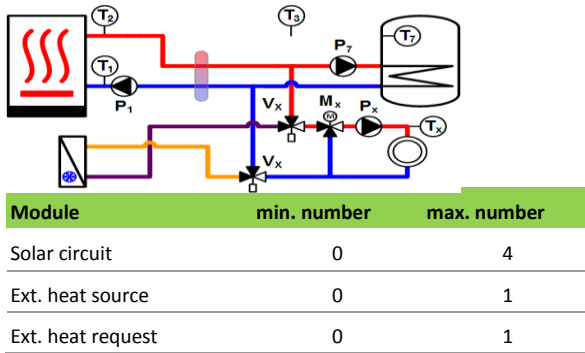

System schema 13

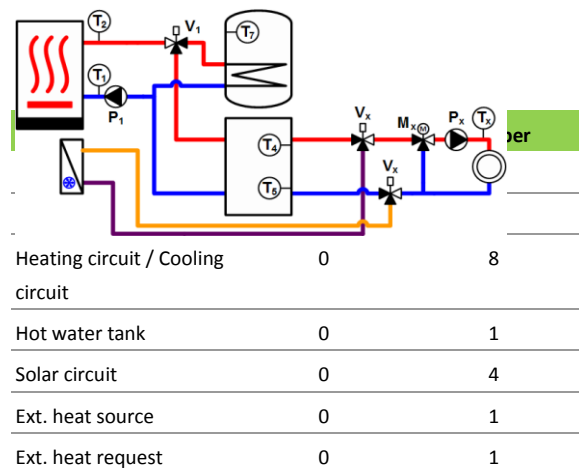

Heat generator, one buffer tank and one hot water tank and optionally an external heat source, external heat request, a switching valve for hot water load and heating/cooling circuits. A heat exchanger is present for passive cooling. Each circuit has its own switching valve. It could also have one for all circuits. This scheme can also be used for a buffer tank with fresh water module when a zone change is available via a valve. The fresh water module has no influence on the control of the heating system. The external heat request requests from the buffer tank.

System schema 12

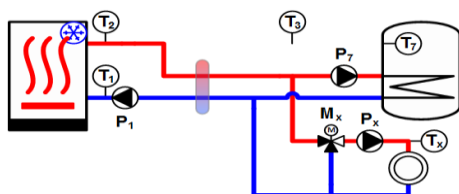

The individual heating/cooling circuits and hot water tanks are connected via a hydraulic separator. Each heating/cooling load must have its own circulation/charge pump. The

external heat request requests from the heat generator.

Module	min. number	max. number
Heat generator / Cold generator	0	4
Buffer	0	0
Heating circuit / Cooling circuit	0	8
Hot water tank	0	4
Solar circuit	0	4
Ext. heat source	0	1
Ext. heat request	0	1

System schema 14

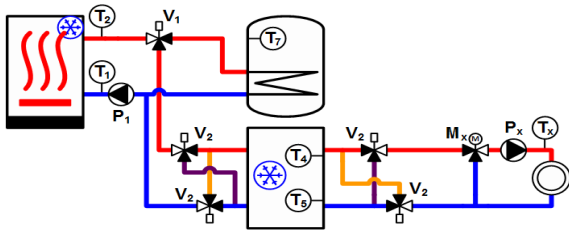

Heat/cooling source, buffer tank, hot water tank and optionally an external heat source, external heat request, reversing valve for hot water load and heating/cooling circuits. Via the priority of the circuits the operating mode of the buffer is determined. In heating mode, the cooling circuits are inactive, in cooling mode, the heating circuits. In the cooling operation, the thermal stratification of the buffer can be changed via a switching valve. The external heat request requests from the buffer tank.

Module	min. number	max. number
Heat generator / Cold generator	0	4
Buffer	1	1
Heating circuit / Cooling circuit	0	8
Hot water tank	0	1
Solar circuit	0	4
Ext. heat source	0	1
Ext. heat request	0	1

System schema 15

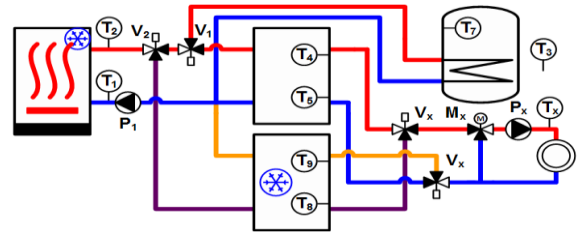

In heating mode, the heat buffer is loaded in the cooling mode, the cooling buffer. Each circuit has its own switching valve. It could also have one for all. This scheme can also be used for a buffer tank with fresh water module when a zone change is available via a valve. The fresh water module has no direct influence on the control of the heating system. The external heat request requests from the heat buffer.

Module	min. number	max. number
Heat generator / Cold generator	0	4
Buffer	2	2
Heating circuit / Cooling circuit	0	8
Hot water tank	0	1
Solar circuit	0	4
Ext. heat source	0	1
Ext. heat request	0	1

System schema 16

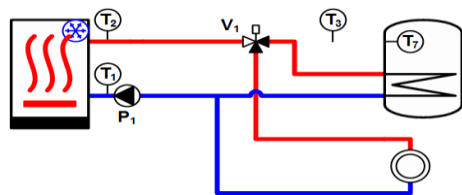

Heat/cooling source, one hot water tank connected via a switching valve and optionally an external heat source, external heat request

Module	min. number	max. number
Heat generator / Cold generator	0	4
Buffer	0	0
Heating circuit / Cooling circuit	0	1
Hot water tank	0	1
Solar circuit	0	4
Ext. heat source	0	1
Ext. heat request	0	1

and at most one unmixed heating/cooling
circuit

System schema 17

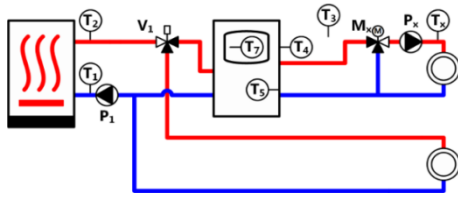

The water heating is done by a buffer tank with an integrated hot water tank or a hot water tank with loading pump. Further heating circuits with circulation pump can be placed after the buffer tank. The external heat request requests from the heat buffer tank.

Module	min. number	max. number
Heat generator / Cold generator	0	4
Buffer	1	1
Heating circuit / Cooling circuit	1	8
Hot water tank	0	4
Solar circuit	0	4
Ext. heat source	0	1
Ext. heat request	0	1

System schema 18

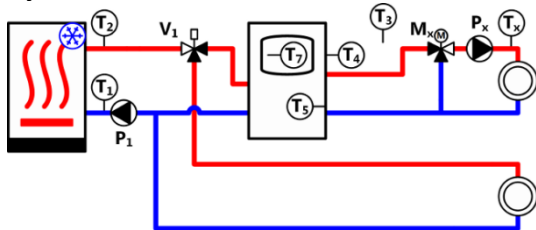

The water heating is done by a buffer tank with an integrated hot water tank or a hot water tank with loading pump. Further heating/cooling circuits with circulation pump can be placed after the buffer tank. The external heat request requests from the heat buffer tank.

Module	min. number	max. number
Heat generator / Cold generator	0	4
Buffer	1	1
Heating circuit / Cooling circuit	1	8
Hot water tank	0	4
Solar circuit	0	4
Ext. heat source	0	1
Ext. heat request	0	1

System schema 19

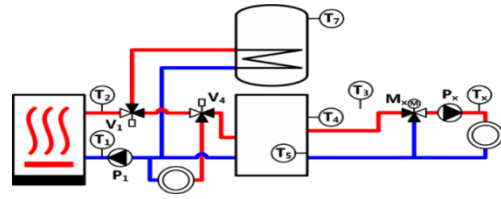

2 switch valves switch between hot water tank, direct unmixed heating circuit and buffer tank. Further heating circuits with circulation pump can be placed after the buffer tank. The external heat request requests from the heat buffer tank.

Module	min. number	max. number
Heat generator	0	4
Buffer	1	1
Heating circuit	1	8
Hot water tank	0	1
Solar circuit	0	4
Ext. heat source	0	1
Ext. heat request	0	1

System schema 20

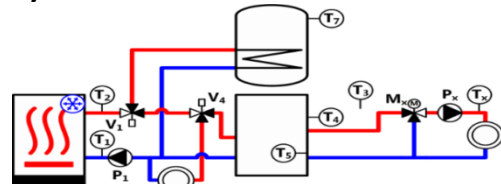

2 switch valves switch between hot water tank, direct unmixed heating/cooling circuit and buffer tank. Further heating/cooling circuits with circulation pump can be placed after the buffer tank. The external heat request requests from the heat buffer tank.

Module	min. number	max. number
Heat generator	0	4
Buffer	1	1
Heating circuit	1	8
Hot water tank	0	1
Solar circuit	0	4
Ext. heat source	0	1
Ext. heat request	0	1

15. Initial operation

Ensure that all valves in the water circuit and the refrigerant circuit are open and that water can flow unimpeded. Check whether all clamps are tight. Make sure that the appliance and the casing are properly closed. Check for refrigerant leaks caused by knocks etc.

16. Commissioning

Before starting the commissioning activities, ensure that the casing and body are firmly mounted and the mechanical work on the heat pump has been completed. Panels and casings must be firmly mounted. It is also important that the electrical connection work is complete before the commissioning activities are started! Now push the main MCB up. The whole heating heat pump is now in setup mode and ready for the setup wizard. After completion, the heat pump is switching in automatic mode. Check whether the condenser input is becoming hot on the refrigerant circuit side and the condenser output is becoming hot on the water side. Make sure that the rotational direction of the compressor is correct. If the rotational direction of the compressor is found to be incorrect, this must immediately be remedied. Use the commissioning protocol, which is part of the warranty conditions, which can be ordered at AT-Tec.

16.1. Commissioning AP420

Station settings	
Systemname	AP420 >
Type	Master >
Heating circuit	none >
Apply	

Detail Menu ► Service ► Stationsettings:

Mask is not available in the web application.

The mask is used for precise specification of the existing station (operating unit):



With **Systemname** a unique name for the master operating unit can be set via an alphanumeric input panel. Touch remote controls have to assign the same systemname as their master operating unit.

Via **Type** can be determined from a dialogue whether the station is a master operating unit or a touch remote control.

If present heating circuits should be operated with this station (e.g. setting the nominal room temperature of the heating circuit) a heating circuit has to be allocated to it via the parameter **heating circuit** from the corresponding text selection menu. The performed settings will be accepted by pressing **APPLY**.

16.2. Commissioning OI420

In the delivery mode, the address is set to 0 (thus heat circuit 1). An address may only be used once in the system for same-type modules! If there are additional OI 423/A with the same address on the system bus, the LED on the OI 423/A blinks alternating between red and orange. The address is set via the service menu. Proceed as follows:

1. Open the service menu by pressing both arrow keys   simultaneously for at least 3 sec. LED1 (left LED on the lower LED semi-circle) lights up and signals the selection of the menu item "Bus address".



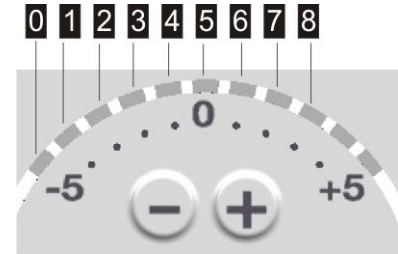

2. Press the buttons "-" and "+" to set the desired address. The top semi-circle is used to display the currently selected address value. The currently specified address value is shown starting with 0 from the left.
The assignment to the desired heating circuit (HC1, HC2, ...) is determined by the address (0, 1, ...) of the OI 423/A
3. Save the entered settings by pushing both arrow keys simultaneously (for three seconds).

The address is now set.



16.3. Setup assistant

The commissioning of a system using the setup assistant is done by the processing of individual steps. In the following masks, the steps of device settings and system scheme are shown exemplarily. Are all steps of the setup assistant processed, the settings entered must be taken by consent. Then the standard layout appears again. In the delivery condition or respectively during the loading of the factory settings, no type is loaded by default. However the parameters are set with default values which represent a heat generator with a small heating power (< 10 kW).

Icon	Description
	Next , for opening the next settings mask of the setup assistant. Press it whenever you are not sure which values you have to change.
	Previous , for opening the previous settings mask of the setup assistant.
	Cancel , for cancelling the setup assistant. The settings made are discarded.
	Help , for opening the help system. Press it whenever you need further assistance.

To start the operation of the heat generating system, proceed as follows:



1. Detail menu:

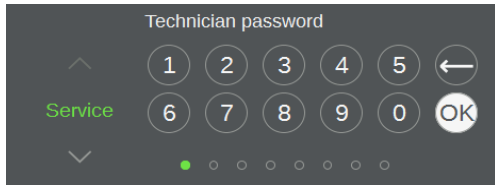

Put in the Service Technician password. If the Service Technician user level is active and the operating unit is not operated for 30 minutes, the system will automatically reset to the normal user mode.

2. Setup assistant:

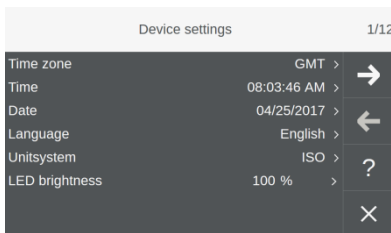

Check the settings of the following screens and if necessary, adjust the parameters by clicking on the different values.

3. Heat sources

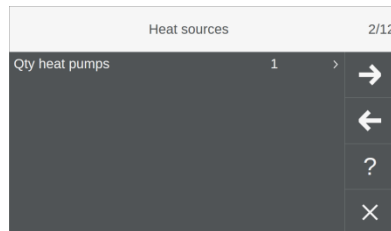

Quantity of heat pumps the system contains.

4. Type selection

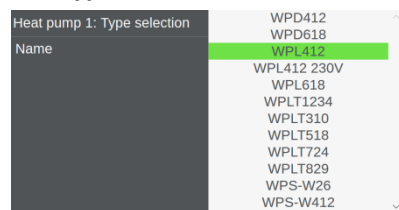

By click on the value, it can be specified which of the existing compressor types with all their basic settings are to be loaded. Depending on the selected type, the parameter settings change in the subsequent masks.

5. Heat pump 1: Energy meter

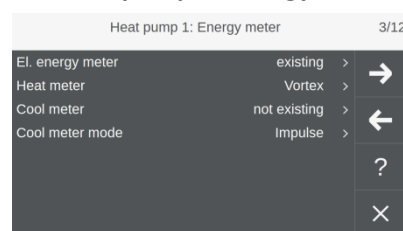

Change values if the listed meters are installed. The chosen settings are required if AT-Tec meters are installed. Wrong values could cause errors.

6. Remote maintenance:

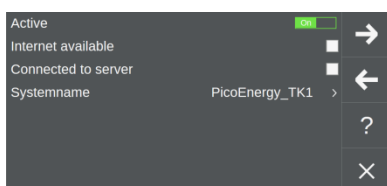

The remote maintenance can be activated via ON/OFF switch. "Internet available" means, that the Internet is available. "Connected to server" will be activated, if there is a contract with AT-Tec to get the KEBA access. "Systemname" designate the unit for the network.

7. Remote maintenance:

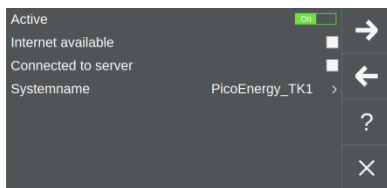

With this remote maintenance, and secure connection can be activated via ON/OFF switch.

“**Internet available**” means, that the Internet is available but not mandatory that a remote maintenance tunnel can be established.

“**Connected to server**” can be activated, if there is a contract with AT-Tec to get the KEBA access.

“**Systemname**” designate the unit for the network.

8. Accept the settings:

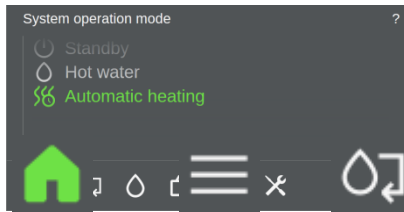

The settings will be applied when exiting the setup mode. Switch to an active system operating mode, by pressing the following buttons:



You have completed the general configuration of the system.

The start up of the heating generator and the heat distribution follows.

16.4. Set-up of heating generator and heat distributing

Detail menu ► System ► Options:

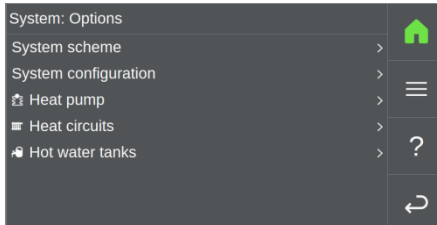

“**System configuration**” means, that you can choose the quantity of your hydraulic parts.

All other menu points are responsible for detailed settings.

For the settings of the heating circuits, use the following guidelines:



For the settings of the screed drying, use the following guidelines:

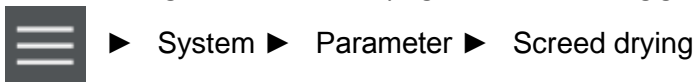

For the settings of the heating circuits, use the following guidelines:



17. Manual mode

The manual mode enables the service technician to manually activate and operate individual components of the heating system. This special system operating mode is activated automatically as soon as parameters of the sub masks are edited. Otherwise a direct activation is effected via the ON/OFF switch of **Manual mode**. An activate manual mode will be displayed on the status bar via the status icon



The duration of the manual operation is defined via the parameter "Start-up time" (default 2 hours) and will be deactivated automatically.

17.1. Testing of the sensors and actuators with manual mode

1. Detail menu ► System ► Manual mode:

"Manual mode" activated via ON/OFF switch.

If activated, all relays are turned off and the  icon will appear on the status bar

2. Heating circuits ► Heating circuits 1-4:

Return to the previous screen and enter "**Heat circuits**"

"Mixer nominal value" push the slider CLOSED/OFF/OPEN to see if the mixer settings changes.

3. If successful, return to the main screen. If the test cause any issues, please resolve now.

4. Press the  icon on the main screen and deactivate the manual mode.

5. Detail menu ► Service ► Save/Load parameters ► Save parameters ► Start saving:

Backup the system configuration.

6. Press two times **Return** and choose **Restart**:

Restart the system to accept the set configurations.

7. The heat generating system is now ready.

18. Alarms and events

The visualization application classifies pending messages into infos, warnings, and errors. Infos are only saved in the event log. Warnings and errors also displayed in the alarm mask. They are used to display possible and actual errors and can provide valuable help for troubleshooting and problem solution.

Depending on the function unit, alarms, warnings, and information are allocated to a certain range of numbers (the alarm list is divided accordingly), which are:

- 00 ... 49 PLC system alarms
- 50 ... 99 Detailed information
- 100 ...199 Heating system alarms
- 500 ... 549 Buffer tank alarms
- 550 ... 599 Hot water tank alarms
- 600 ... 699 Heating circuit alarms
- 700 ... 799 Solar circuit alarms
- 800 ... 849 External heat request alarms
- 850 ... 900 External heat source alarms
- 1000 ... 1100 Heat pump alarms
- 1000 ... 1100 Heat pump alarms

ID	Class	Designation	(Possible) cause/effect	Rectification/action	Quit
15	Error	Invalid parameter	The parameter of the object is invalid. If the error appears during the start-up process, the object will not be created (no instance). If the error appears during the operation due to a user entry, the entry will be rejected.	If the error appears during the start-up process, the formula file needs to be checked.	Yes
21	Error	Invalid station ID	The station ID was not set yet. The communication bus is not functional.	Restart control and set the station ID via the visualization.	Yes
22	Error	Communication error Boiler module	The communication to the listed module has been aborted. Functional units based on this module are not operating	Check bus connection, bus address, power supply of the affected IO-module.	No
23	Error	Communication error Heating circuit module	The communication to the listed module has been aborted. Functional units based on this module are not operating	Check bus connection, bus address, power supply of the affected IO-module.	No
24	Warning	Communication error Digital remote control	The communication to the digital remote control has been aborted. The digital remote control can no longer be used to enter any input.	Check the bus connection, bus address, power supply of the affected digital remote control.	No
25	Warning	Communication error Touch remote control	The communication to the remote control has been aborted. The remote control can no longer be used to enter any input.	Check the bus connection, bus address, power supply of the affected remote control.	No
26	Error	Communication error Heat pump modul	The communication to the listed module has been aborted. Functional units based on this module are not operating	Check bus connection, bus address, power supply of the affected IO-module.	No
27	Error	Overtemperature Heat pump modul	The permissible operating temperature has been exceeded. Functional units based on this module are not operating	Let the module cool down, check ventilators if applicable.	No
28	Error	Emergency stop Heat pump modul	Criteria for an emergency shutdown have been triggered. Functional units based on this module are not operating	Check heat pump, sensors, actuators.	No

ID	Class	Designation	(Possible) cause/effect	Rectification/action	Quit
29	Warning	Address conflict Touch remote control	2 or more touch remote controls with identical address exist. The touch remote control processes no inputs	Check address in visualization.	No
30	Warning	Manual mode terminated	The manual mode of the object will be terminated due to an error. The object switches to the normal operating status.	The message must be confirmed.	Yes
32	Error	Communication error Frequency converter ATV	The communication to the listed module has been aborted. Functional units based on this module are not operating	Check bus connection, bus address, power supply of the affected IO-module.	no
33	Error	ATV malfunction	Frequency converter has malfunction. Functional units based on this module are not operating	Check wiring, power supply and bus connection.	no
34	Error	Communication error Frequency converter Power	The communication to the listed module has been aborted. Functional units based on this module are not operating	Check bus connection, bus address, power supply of the affected IO-module.	no
35	Error	Power malfunction	Frequency converter has malfunction. Functional units based on this module are not operating	Check wiring, power supply and bus connection.	no
50	Info	Sensor failure	The sensor reports an (internal) error.	-	-
51	Info	Sensor measuring range undercut	The sensor reports undercut values for the measuring range.	-	-
52	Info	Sensor measuring range exceeded	The sensor reports exceeded values for the measuring range.	-	-
53	Info	Sensor break	The sensor reports sensor failure and is not functional.	Check the wiring to the sensor.	-
54	Info	Sensor short circuit	The sensor reports a short-circuit. The sensor is not functional.	Check the wiring to the sensor.	-

ID	Class	Designation	(Possible) cause/effect	Rectification/action	Quit
55	Info	Sensor plausibility check failed	The sensor value is outside of the stated plausibility range.	-	-
56	Info	Sensor type not defined	The sensor type is not specified. The sensor is not functional.	-	-
57	Info	Sensor input not populated	Sensor input is not populated on IO board circuit. Sensor is not usable.	Modify IO assignment.	-
60	Info	Actuator failure	The actuator reports an (internal) error.	-	-
61	Info	Actuator overload	The actuator reports an overload.	-	-
62	Info	Actuator overheat	The temperature monitoring of the actuator has been triggered.	-	-
65	Info	Actuator power monitoring defective	The power monitoring system of the actuator has an error.	-	-
66	Info	Actuator excess power	The power monitoring system of the actuator has detected that the power limit has been exceeded.	-	-
67	Info	Actuator insufficient power	The power monitoring system of the actuator has detected that the power limit has been undercut.	-	-
68	Info	Actuator group error	Error monitoring has detected an error.	-	-
70	Info	Self-test failed	The self-test of the unit has failed.	-	-
71	Info	Plausibility check failed	The unit reports an error due to a plausibility check.	-	-
72	Info	Timeout exceeded	The unit reports an error due to exceeded time limit.	-	-
73	Info	Pause time active	The unit cannot be activated because a pause time must be observed.	-	-

ID	Class	Designation	(Possible) cause/effect	Rectification/action	Quit
74	Info	Maximum On-time exceeded	The unit has deactivated itself because a time monitoring system, which monitors the maximum On-time, has been triggered.	-	-
75	Info	Maximum number of attempts exceeded	The maximum number of attempts has been reached.	-	-
76	Info	Control monitoring	The control circuit monitoring system has detected an impending instability of the control circuit.	-	-
77	Info	Open loop control	The actuator of the unit will be controlled directly due to an error of the sensor or the control circuit monitoring system.	-	-
78	Info	Overtemperature	The permissible operating temperature has been exceeded.	-	-
79	Info	Subnormal temperature	A subnormal temperature was detected in the unit.	-	-
90	Info	Not Stable Yet	The unit works, however, it has not reached a stable (fixed) state.	-	-
100	Warning	Exterior temperature sensor	The exterior temperature sensor is defective. The exterior temperature will not be taken into consideration for the calculation of the inflow temperature of the heating circuits.	The exterior temperature sensor or its wiring must be checked.	No
105	Warning	Flow temperature sensor	The inflow temperature sensor of the heating system is defective. If possible, the temperature of the heat generating system or the temperature of the external heat source will be used as an inflow temperature.	The inflow temperature sensor or its wiring must be checked.	No
106	Warning	Frost protection active	The frost monitoring system has detected an insufficient inflow temperature of the heating system below the frost protection limit. A heat request is triggered.	-	No
107	Warning	Frost protection alarm	The frost monitoring system has detected an insufficient inflow temperature of the heating	Primarily, look at the other alarms. These are probably the cause of the	Yes

ID	Class	Designation	(Possible) cause/effect	Rectification/action	Quit
			system below the frost protection alarm limit. The system is at risk to be damaged by frost.	standstill of the system. A rectification of those should also cancel the frost protection alarm.	
108	Error	Network pump	The network pump reports an error. The network pump is not ready for operation.	The network pump or its cabling must be checked.	No
109	Error	Network pump deactivated	An incorrect parameter setting was found during the start-up process. The network pump is not active.	Check and correct assigned parameters. Restart system.	Yes
110	Error	Switch valve deactivated	An incorrect parameter setting was found during the start-up process. The switch valve is not active.	Check and correct assigned parameters. Restart system.	Yes
111	Warning	Batteries almost empty	Batteries of the affected radio remote control are almost empty. The affected radio remote control will soon switch of.	Change batteries of the affected radio remote control	No
112	Error	Photovoltaic deactivated	Incorrect parameterization detected during startup. Photovoltaic is not active.	Check and adept parameterization. Restart system.	Yes
500	Warning	Frost protection active	The frost monitoring system has detected an insufficient water temperature below the frost protection limit. A heat request is triggered.	-	No
501	Warning	Frost protection alarm	The frost monitoring system has detected an insufficient water temperature below the frost protection alarm limit. The buffer storage is at risk to be damaged by frost.	Primarily, look at the other alarms. These are probably the cause of the standstill of the system. A rectification of those should also cancel the frost protection alarm. If this does not fix the alarm, please contact customer service immediately.	Yes
510	Warning	Sensor top temperature	The top temperature sensor of the buffer storage is defective. The buffer storage is not	The top temperature sensor of the buffer	No

ID	Class	Designation	(Possible) cause/effect	Rectification/action	Quit
			ready for operation. It does not provide a heat request.	storage or its wiring must be checked.	
511	Error	Excessive temperature	The monitoring of the top buffer temperature - has been triggered. No heat request is triggered.		No
513	Warning	Sensor bottom temperature	The top temperature sensor of the buffer storage is defective. The buffer storage is in the emergency operation mode. The top temperature is used.	The bottom temperature sensor of the buffer storage or its wiring must be checked.	No
514	Error	Buffer deactivated	An incorrect parameter setting was found during the start-up process. The buffer is not active.	Check and correct assigned parameters. Restart system.	Yes
550	Warning	Frost protection active	The frost monitoring system has detected an insufficient water temperature below the frost protection limit. A heat request is triggered.	-	No
551	Warning	Frost protection alarm	The frost monitoring system has detected an insufficient water temperature below the frost protection alarm limit. The hot-water tank is at risk to be damaged by frost.	Primarily, look at the other alarms. These are probably the cause of the standstill of the system. A rectification of those should also cancel the frost protection alarm. If this does not fix the alarm, please contact customer service immediately.	Yes
560	Warning	Sensor top temperature	The top temperature sensor of the hot-water tank is defective. The hot-water tank is in emergency operation mode.	The top temperature sensor of the hot-water tank or its wiring must be checked.	No
561	Error	Excessive temperature	The temperature of the hot-water tank has exceeded the maximum permitted temperature. No heat request is triggered.	-	No

ID	Class	Designation	(Possible) cause/effect	Rectification/action	Quit
563	Error	Heat request timeout	Force loading with defective top temperature sensor or the hot-water tank did not get hot.	Repeat loading process	Yes
564	Error	Hot-water tank pump	The hot-water tank loading pump reports an error. The hot-water tank is not ready for operation.	The hot-water tank loading pump or its cabling must be checked.	No
565	Warning	Hot-water tank circulation pump	The hot-water tank circulation pump reports an error. The hot-water tank circulation pump is not ready for operation.	The hot-water tank circulation pump or its cabling must be checked.	No
566	Error	Hot-water tank deactivated	An incorrect parameter setting was found during the start-up process. The hot-water tank is not ready for operation.	Check and correct assigned parameters. Restart system.	Yes
567	Error	Hot water tank heat pump	The hot water tank heat pump has an error The hot water tank is not ready for operation.	The hot water heat pump and its wiring has to be checked.	No
568	Warning	Hot water tank aux. heater	The hot water tank auxiliary heater has an error. The hot water tank auxiliary heater is not ready for operation.	The hot water tank auxiliary heater and its wiring has to be checked.	No
569	Warning	Hot water tank leg. timeout	Legionella disinfection time out Broken temperature sensor or hot water tank didn't get hot.	Check why the top temperature didn't get high enough.	Yes
600	Warning	Frost protection active	The frost monitoring system has detected an insufficient inflow water temperature below the frost protection limit. A heat request is triggered.	-	No
601	Warning	Frost protection alarm	The frost monitoring system has detected an insufficient water temperature below the frost protection alarm limit. The heating circuit is at risk to be damaged by frost.	Primarily, look at the other alarms. These are probably the cause of the standstill of the system. A rectification of those should also cancel the frost protection alarm. If this does not fix the alarm, please contact	Yes

ID	Class	Designation	(Possible) cause/effect	Rectification/action	Quit
				customer service immediately.	
609	Warning	Radio remote control offers invalid values	An invalid value had been received from the radio remote control(RRC). Values from the RRC are ignored.	The RRC must be checked.	No
610	Error	Mixer group	The mixer group of the heating circuit is defective. The heating circuit is not ready for operation.	The mixer group (inflow temperature, pump, mixer) of the heating circuit must be checked.	No
611	Warning	Sensor room temperature	The room temperature sensor is defective. The inflow temperature is determined based on the exterior temperature and a supposed room temperature of 20,0° C.	The exhaust gas temperature sensor or its wiring must be checked.	No
612	Warning	Digital remote control	An invalid value was received by the digital remote control (DRC). The values of the DRC are ignored.	The DRC must be checked.	No
613	Error	Pump heating circuit	The pump of the heating circuit is defective. The heating circuit is not ready for operation.	The pump of the heating circuit must be checked.	No
614	Error	Heating circuit deactivated	An incorrect parameter setting was found during the start-up process. The heating circuit is not active.	Check and correct assigned parameters. Restart system.	Yes
615	Warning	Screed Drying	Screed drying settings have to be checked before resuming. Screed drying is not started until confirmation.	Confirm message	Yes
616	Warning	Sensor room humidity	The humidity room sensor is defect. Cooling function is deactivated.	The humidity room sensor and its wiring must be proved.	No
617	Warning	Sensor reflux temperature	Reflux temperature sensor is broken. Reflux supervision is disabled.	Reflux temperature sensor and its wiring has to be checked.	No
700	Error	Sensor collector temperature	The temperature sensor collector is defective. The solar system is not ready for operation.	The sensor or its wiring must be checked.	No

ID	Class	Designation	(Possible) cause/effect	Rectification/action	Quit
701	Error	Sensor flow temperature	The inflow temperature sensor for the heat volume of the solar system is defective. . The heat volume cannot be calculated.	The sensor or its wiring must be checked.	No
702	Error	Sensor reflux temperature	he reflux temperature sensor for the heat volume of the solar system is defective. The heat volume cannot be calculated.	The sensor or its wiring must be checked.	No
703	Error	Solar pump	The pump of the 1st circuit of the solar system is defective. The 1st circuit of the solar system is not ready for operation.	The pump or its cabling must be checked.	No
704	Error	Solar pump	The pump of the 2nd circuit of the solar system is defective. The 2nd circuit of the solar system is not ready for operation.	The pump or its cabling must be checked.	No
707	Warning	Excessive temperature	The collector temperature has exceeded the maximum collector temperature set in the parameters. The solar pump will be deactivated.	Wait until the temperature has fallen.	No
708	Warning	Excessive temperature	The temperature of the solar consumer has exceeded the maximum temperature set in the parameters. The heat request is withdrawn.	Wait until the temperature has fallen.	No
709	Error	Sensor reference temperature	The reference temperature sensor of the solar consumer is defective. Solar consumer is not ready for operation.	The sensor or its wiring must be checked.	No
710	Warning	Heat meter	The inflow or reflux temperature sensor or the metered input for the heat volume of the solar system is defective. The heat volume cannot be calculated.	The sensor or the corresponding wiring must be checked.	No

ID	Class	Designation	(Possible) cause/effect	Rectification/action	Quit
711	Error	Solar circuit deactivated	An incorrect parameter setting was found during the start-up process. The solar circuit is not active.	Check and correct assigned parameters. Restart system.	Yes
712	Error	Solar consumer deactivated	An incorrect parameter setting was found during the start-up process. The solar consumer is not active.	Check and correct assigned parameters. Restart system.	Yes
800	Error	Heat request DI	The digital input of the external heat request is defective. External heat request is not ready for operation.	The heat request DI or its wiring must be checked.	No
801	Warning	Heat request temperature AI	The analog input of the external heat request is defective. The external heat request is only operated with the digital input.	The heat request temperature AI or its wiring must be checked.	No
802	Error	Heat request deactivated	An incorrect parameter setting was found during the start-up process. The external heat request is not active.	Check and correct assigned parameters. Restart system.	Yes
860	Warning	Temperature sensor ext. heat source	The temperature sensor of the external heat source is defective. The temperature cannot be monitored.	The temperature sensor of the external heat source or its wiring must be checked.	No
861	Error	Ext. heat source	The digital output to request the external heat source is defective. The external heat source cannot be requested.	The digital output or its wiring must be checked.	No
862	Error	Ext. heat source	The analog output to request the external heat source is defective. The external heat source cannot be requested.	The analog output or its wiring must be checked.	No

ID	Class	Designation	(Possible) cause/effect	Rectification/action	Quit
863	Error	Ext. heat source deactivated	An incorrect parameter setting was found during the start-up process. The external heat source is not active.	Check and correct assigned parameters. Restart system.	Yes
900	Error	Heat sources management deactivated	An incorrect parameter setting was found during the start-up process. The heat sources management is not active.	Check and correct assigned parameters. Restart system.	Yes
1000	Error	Heat pump deactivated	An incorrect parameter setting was found during the start-up process. The heat pump is not active.	Check and correct assigned parameters. Restart system.	No
1001	Warning	Frost protection active	The frost monitoring system has detected an insufficient water temperature below the frost protection limit. The heat pump is not active.	-	No
1002	Warning	Frost protection alarm	The frost monitoring system has detected an insufficient water temperature below the frost protection limit. The heat pump is at risk to be damaged by frost.	Primarily, look at the other alarms. These are probably the cause of the standstill of the system. A rectification of those should also cancel the frost protection alarm.	Yes
1003	Error	Sensor temperature compressor in	The temperature sensor is defective. The heat pump is not ready for operation and will be turned off.	The temperature sensor or its wiring must be checked.	No
1004	Error	Sensor temperature compressor out	The temperature sensor is defective. The heat pump is not ready for operation and will be turned off.	The temperature sensor or its wiring must be checked.	No
1005	Error	Max. compressor out temperature	Maximum temperature compressor output exceeded. The heat pump is not ready for operation and will be turned off.	The heat pump can only be reactivated when the temperature at the compressor output falls below the parameterized value.	No
1006	Error	Sensor temperature source in	The temperature sensor is defective. The heat pump is not ready for operation and will be turned off.	The temperature sensor or its wiring must be checked.	No

ID	Class	Designation	(Possible) cause/effect	Rectification/action	Quit
100 7	Error	Sensor temperature source out	The temperature sensor is defective. The heat pump is not ready for operation and will be turned off.	The temperature sensor or its wiring must be checked.	No
100 8	Error	Sensor temperature flow	The temperature sensor is defective. The heat pump is not ready for operation and will be turned off.	The temperature sensor or its wiring must be checked.	No
100 9	Error	Sensor temperature reflux	The temperature sensor is defective. The heat pump is not ready for operation and will be turned off.	The temperature sensor or its wiring must be checked.	No
101 0	Error	Limit switch high pressure	The high-pressure switch threshold has been exceeded. The heat pump is not ready for operation and will be turned off.	The heat pump can only be reactivated when the pressure falls below the parameterized value.	No
101 1	Error	Limit switch low pressure	Threshold vacuum switch undercut The heat pump is not ready for operation and will be turned off.	The heat pump can only be reactivated when the pressure rises above the parameterized value.	No
101 2	Error	Sensor high pressure	The pressure sensor is defective. The heat pump is not ready for operation and will be turned off.	The pressure sensor or its wiring must be checked.	No
101 3	Error	High pressure	Maximum pressure limit exceeded The heat pump is not ready for operation and will be turned off.	The heat pump can only be reactivated when the pressure falls above the parameterized value.	No
101 4	Error	Sensor low pressure	The pressure sensor is defective. The heat pump is not ready for operation and will be turned off.	The pressure sensor or its wiring must be checked.	No
101 5	Error	Low pressure	Minimum pressure limit undercut The heat pump is not ready for operation and will be turned off.	The heat pump can only be reactivated when the pressure rises above the parameterized value.	No
101 6	Error	Max. flow temperature	Maximum inflow temperature inflow exceeded	The heat pump can only be reactivated when the inflow temperature falls	No

ID	Class	Designation	(Possible) cause/effect	Rectification/action	Quit
			The heat pump is not ready for operation and will be turned off.	below the parameterized value.	
101 7	Error	Sensor supervision	Multiple occurrences of sensor errors within the monitoring period. The heat pump is not active until the error will be confirmed.	The message must be confirmed. The sensors or their cabling must be checked.	Yes
101 8	Error	Source side supervision	Multiple occurrences of errors on the source side within the monitoring period. The heat pump is not active until the error will be confirmed.	The message must be confirmed. The sensors and actuators or their cabling must be checked.	Yes
101 9	Error	Refrigeration cycle supervision	Multiple occurrences of errors in the cooling circuit monitoring system within the monitoring period. The heat pump is not active until the error will be confirmed.	The message must be confirmed. The sensors and actuators or their cabling must be checked.	Yes
102 0	Error	Heating side supervision	Multiple occurrences of errors on the heating water side within the monitoring period. The heat pump is not active until the error will be confirmed.	The message must be confirmed. The sensors and actuators or their cabling must be checked.	Yes
102 1	Error	Min. source in temperature	Minimum source input temperature undercut. The heat pump is not ready for operation and will be turned off.	The heat pump can only be reactivated when the temperature rises above the parameterized value.	No
102 2	Error	Min. source out temperature	Minimum source input temperature undercut. The heat pump is not ready for operation and will be turned off.	The heat pump can only be reactivated when the temperature rises above the parameterized value.	No
102 3	Error	Min. reflux temperature	Minimum reflux temperature undercut The heat pump is not ready for operation and will be turned off.	The heat pump can only be reactivated when the temperature rises above the parameterized value.	No

ID	Class	Designation	(Possible) cause/effect	Rectification/action	Quit
102 4	Error	Sensor temperature condenser	The temperature sensor is defective. The heat pump is not ready for operation and will be turned off.	The temperature sensor or its wiring must be checked.	No
102 5	Error	Compressor	The compressor has an error. The heat pump is not ready for operation and will be turned off.	The compressor or its wiring must be checked.	No
102 6	Error	Source failure	Source supervision triggered. The heat pump is not ready for operation and will be turned off.	The heat source must be checked.	No
102 7	Error	Actuator source broken	The source actuator of the heat pump has an error. The heat pump is not ready for operation and will be turned off.	The source actuator or its wiring must be checked.	No
102 8	Error	Phase failure	Phase failure in the 3-way current supply. The heat pump is not ready for operation and will be turned off.	In case of disruptions by the network carrier, wait for the duration, check cabling.	No
102 9	Error	Variable frequency device	The frequency converter has an error. The heat pump is not ready for operation and will be turned off.	The frequency converter or its wiring must be checked.	No
103 0	Error	Defrosting Circuit Inversion	Timer for starting circuit invasion has elapsed. Auxiliary heating couldn't heat up enough for starting defrosting via circuit invasion.	Check auxiliary heating and heat pump.	Yes
103 1	Error	Defrosting Timeout	Maximum retry for finishing defrosting reached. Heat pump is not operational.	Check heat pump.	Yes
103 2	Error	Overheat control	Overheat control broken. Electronic expansion valve stays closed.	Check sensors and wiring. Check parameterization of controller.	No
103 3	Error	Min. flow temperature	Temperature is below limitation. Heat pump is not operational.	Heat pump is operational again, when temperature rises above parameterized limit.	No

ID	Class	Designation	(Possible) cause/effect	Rectification/action	Quit
103 4	Error	Sensor temperature passive cooling	Passive cooling temperature sensor is broken. Check sensor and wiring. Heat pump is not operational.		No
103 5	Warning	Passive cooling supervision	Temperature in the passive cooling exchanger - is below limit or the heat pump sets a source side flow supervision warning. Passive cooling requests are disabled temporary.		No
103 6	Error	Passive cooling deactivated	Incorrect parameterization detected during startup. Passive cooling is deactivated.	Check parameterization and restart system.	No
103 7	Error	Flow monitor	Too less source side flow. Heat pump is not operational.	Prove the source for failures.	No

19. Web application

The web operation provides a lightly limited functionality with respect to the display and the parameter setting options, masks and input dialogs. All masks and parameters which directly affect the operating unit (like "Screen saver, Brightness,...") are not available in the web application.

19.1. Tested platforms and web browsers

"Mozilla Firefox" is recommended as browser on PC.

PC + Windows 7

- Mozilla Firefox
- Version: 37.0.2
- Internet Explorer
- Version: 11.0.9600.17728IS

Samsung Galaxy Nexus + Android 4.2.1

- Google Chrome
- Version: 42.0.2311.108

Tablet Google Nexus 10 + Android 5.1.1

- Google Chrome
- Version: 42.0.2311.109

iPhone4, 5c, iPad2, iPad mini

- Apple Safari
- Version: defined by iOS

19.2. Connection PC to operating unit

Prerequisite: Router on the Ethernet of the system

To display the web application via an internet browser enter the name of your AP 420 (e.g. ap420_0.local.) or the IP address of your AP 420 (e.g. http://10.150.61.1) in the address line of the Internet browser. Upon completed authentication, the web application is released for operation and the home mask appears.

19.3. Connection smart phone to operating unit

Prerequisite: WLAN router on the Ethernet of the system

Activate WLAN on the smart phone and open your mobile browser and enter the name of your AP 420 (e.g. ap420_0.local.) or the IP address of your AP 420 (e.g. http://10.150.61.1) in the address line of the Internet browser. Upon completed authentication, the web application is released for operation and the home mask appears.

19.4. Connection setup via remote access outside the local network

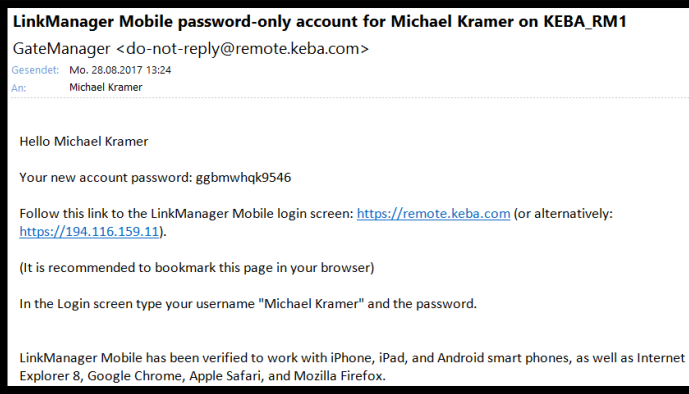

After setting up the portal access, the access data will be sent to your state e-mail address.

Follow the instructions as shown in the e-mail. Afterwards you will be taken to the overview screen in which you see the attachments assigned to them.

Click on the appropriate attachment:



Click on "WebHmi":



Click on "www" and get access to the visualisation

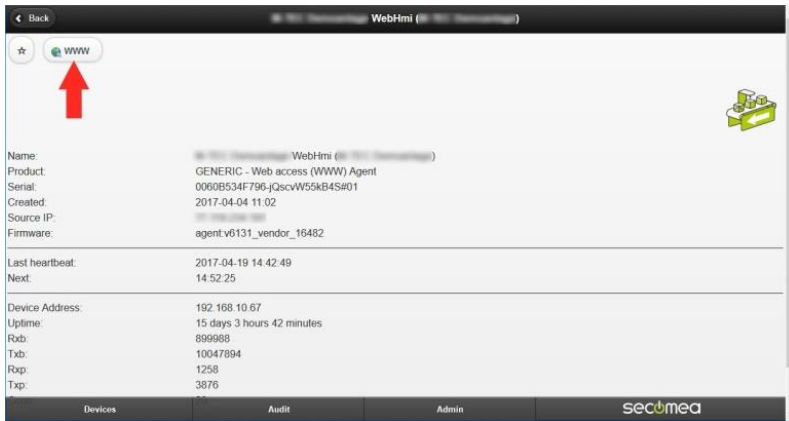

20. Prepare USB stick for service functions

To prevent problems with respect to data security and mechanical plug connection, the use of a USB stick model "SLUFD1GU2TU" made by STEC has been successful. This is a non-committal recommendation from AT-Tec.

Prepare USB sticks for use as update stick:

For this purpose the file "createUpdateStick.bat" included in the scope of delivery is needed. If you have a suitable USB stick and the ".bat" file, you can now prepare the USB stick. For that, please follow the individual steps of the instruction.

1. Copy the ".bat" file onto your PC.
2. Insert a suitable USB stick into a USB port on your PC.
3. Execute the ".bat" file by double-clicking.
4. Follow the instructions and messages on the screen.
5. After a message indicating the completion of the preparation process is displayed, you can disconnect the USB stick via the Icon "Safely Remove Hardware" in the task bar and pull out the USB stick.

21. Handover to end customer

Once installation is complete and the system has been tested to ensure that it is functioning correctly, the operating instructions must be explained to the operator and its attention must be drawn to the following points in the operating instructions:

- Important informations and Safety Informations
- Refrigerant R410A
- Cleaning and care
- Operation and Display

The operator must also be informed that unauthorised work on the heat pump invalidates the warranty.

22. Cleaning and care

A periodic maintenance is necessary first of all to keep a correct and efficient operation of the heat pump, in order to reduce wear and deterioration of components. The frequency of interventions is decided by the user, and mainly it depends from two factors:

- Dirt can be removed from the surface with a damp cloth and commercially available cleaning agents.

- Lubricant and sealant residues and oxidation can contaminate the heating water. The heating water must therefore be checked at regular intervals. If contamination is detected, the heating water must be cleaned.
- The heating system may only be cleaned by an authorised contractor.
- The water pressure in the heating system must be regularly checked, as fault-free operation is not possible if there is insufficient heating water.
- If a drop in water pressure is detected, the system should be topped up with water.
- In case of a tank with anodic corrosion protection, the anode must be checked at least once a year. Replace the anodic corrosion protection if it is used up. Check the anode more frequently if the water is aggressive.

23. Warranty information

If one or more of these points apply, AT-Tec cannot be held liable for its products by third parties. The warranty is invalidated if:

- servicing and maintenance has not been carried out in accordance with requirements, repairs have not been performed by AT-Tec personnel or have been performed without prior written consent from AT-Tec.
- modifications to the system have been carried out without prior written consent from AT-Tec.
- settings and safety devices have been modified without prior written consent from AT-Tec.
- refrigerants or lubricants other than the original ones or other than those prescribed have been used.
- the system was not installed and/or connected in accordance with the installation instructions.
- the system is being used improperly, incorrectly, negligently or not in accordance with its design and/or its intended purpose.

24. Disposal

The operator is responsible for proper disposal of the heat pump and all operating fluids and cleaning agents. The industry-specific and local regulations for the disposal of different materials must be observed. The heat pump may only be dismantled and disposed of by qualified personnel.

The refrigerant must be recycled or disposed of in accordance with the European directive relating to fluorinated greenhouse gases.

- Disconnect the heat pump from the supply lines/cables (water and electricity). Ensure that no other devices are affected by this.
- Make sure that all supply lines/cables to be detached have zero voltage and are unpressurised.
- Remove all operating and auxiliary materials (e.g. refrigerant) and dispose of them in an environmentally appropriate manner.
- Disassemble the heat pump until all system parts can be assigned to a material group and disposed of accordingly.
- Dispose of the heat pump in an environmentally responsible manner. Observe national regulations.

25. Safety datasheet

Because this is a closed refrigerant circuit, it is not expected that a refrigerant leakage occurs. However should a refrigerant leak occur follow the advices of the safety data sheet.

Safety datasheet R410A

1 IDENTIFICATION OF THE SUBSTANCE/PREPARATION AND OF THE COMPANY

Product name

R410A

Trade name

R410A

Components/Impurities

Contains the following components:

50% w/w Difluoromethane (R32) {F+;R12} {EINECS No. 200-839-4}

50% w/w Pentafluoroethane (R125) {EINECS No. 206-557-8}

Relevant identified uses

Industrial and professional. Perform risk assessment prior to use.

Uses advised against

Consumer use.

Company identification

BOC, Priestley Road, Worsley, Manchester M28 2UT

E-Mail Address ReachSDS@boc.com

Emergency phone numbers (24h): 0800 111 333

2 HAZARDS IDENTIFICATION

EC Classification

Not classified as dangerous preparation.

In high concentrations may cause asphyxiation

Risk advice to man and the environment

Liquefied gas.

3 COMPOSITION/INFORMATION ON INGREDIENTS

Substance/Preparation: Preparation.

Components/Impurities

Contains the following components:

1,1,1,2,2 -Pentafluoroethane (R 125) 50 %

CAS No: 354-33-6 **EINECS No.:** 206-557-8

EC classification of pure substance:

Proposed by the industry

Not classified as a dangerous substance.

In high concentrations may cause asphyxiation.

Difluoromethane (R 32) 50 %

CAS No: 75-10-5 **EINECS No.:** 200-839-4

EC classification of pure substance:

Proposed by the industry

F+; R12

Contains no other components or impurities which will influence the classification of the product.

4 FIRST AID MEASURES

Inhalation

In low concentrations may cause narcotic effects. Symptoms may include dizziness, headache, nausea and loss of co-ordination.

In high concentrations may cause asphyxiation. Symptoms may include loss of mobility/consciousness. Victim may not be aware of asphyxiation.

Remove victim to uncontaminated area wearing self contained breathing apparatus. Keep victim warm and rested. Call a doctor.

Apply artificial respiration if breathing stopped.

Skin/eye contact

In case of frostbite spray with water for at least 15 minutes. Apply a sterile dressing.

Immediately flush eyes thoroughly with water for at least 15 minutes.

Remove contaminated clothing. Drench affected area with water for at least 15 minutes

Obtain medical assistance

Ingestion

Ingestion is not considered a potential route of exposure.

5 FIRE FIGHTING MEASURES

Specific hazards

Exposure to fire may cause containers to rupture/explode. Non flammable.

Hazardous combustion products

If involved in a fire the following toxic and/or corrosive fumes may be produced by thermal decomposition:

Carbonyl fluoride, Hydrogen fluoride, Carbon monoxide.

Suitable extinguishing media

All known extinguishants can be used.

Specific methods

If possible, stop flow of product. Move container away or cool with water from a protected position.

Special protective equipment for fire-fighters

Use self-contained breathing apparatus and chemically protective clothing.

6 ACCIDENTAL RELEASE MEASURES

Personal precautions

Evacuate area. Wear self-contained breathing apparatus when entering area unless atmosphere is proved to be safe. Ensure adequate air ventilation.

Environmental precautions

Prevent from entering sewers, basements and workpits, or any place where its accumulation can be dangerous. Try to stop release.

Clean up methods

Ventilate area.

7 HANDLING AND STORAGE

Handling

Suck back of water into the container must be prevented. Do not allow backfeed into the container. Use only properly specified equipment which is suitable for this product, its supply pressure and temperature. Contact your gas supplier if in doubt. Refer to supplier's handling instructions.

Storage

Keep container below 50°C in a well ventilated place. Secure cylinders to prevent them from falling.



Distributeur en specialist duurzame installatietechniek
Pallasweg 13
8938 AS Leeuwarden
058 – 288 47 39
info@technea.nl
www.technea.nl