

JUAL

CABLE FLASHING (Ø50)



PRODUCT DESCRIPTION

JUAL Cable Flashing (Ø50)

APPLICATION:

For leading cables through bitumen and foil roof membranes.

MATERIALS:

Flange: 1,5 mm stainless steel, AISI 304.

Pipe/bend: Stainless steel, AISI 316.

Membrane: Bitumen or foil. To be specified at ordering.



TÜVRheinland®

Precisely Right.

This product is tested and certified according to EN 1253.

ARTICLE NUMBERS

TYPE	DIAMETER	ARTICLE NO.	MEMBRANE
JUAL Cable Flashing (Ø50)	Ø50	220054-xxx	<p>Eks.: 60050-600-xxx</p> <p>"xxx" is the membrane code</p> <p>Example: SBS: code 101</p> <p>Membrane list can be found at www.jual.dk</p>



TECHNICAL DATA SHEET

TECHNICAL INFORMATION

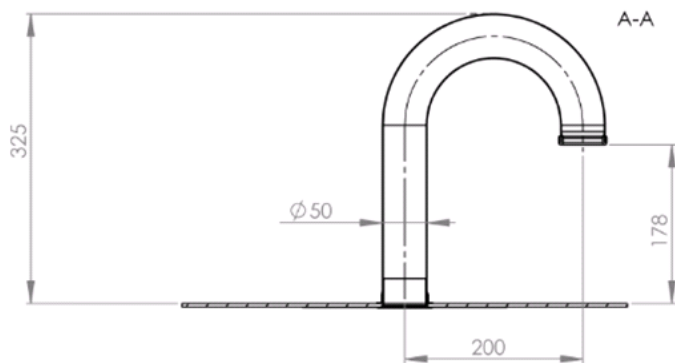
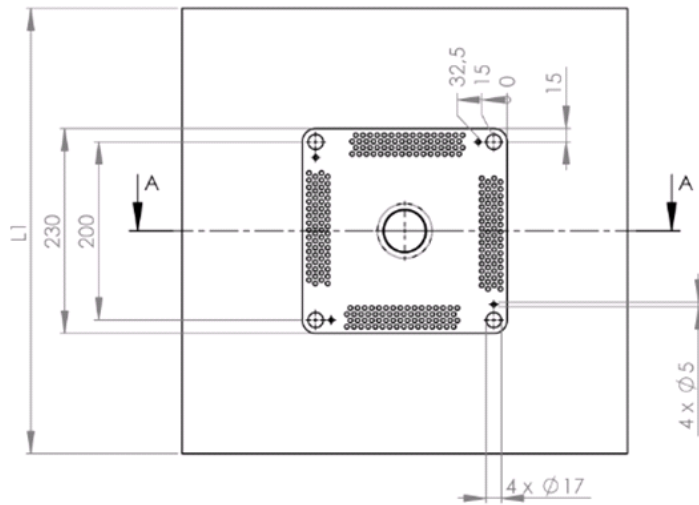

L1	
BITUMEN	FOIL
500x500	330x330

APPROVALS

The cable flashing is approved and certified according to EN 1253 which specifies requirements for construction and function, and manufactured in accordance with DIN 18200, which specifies requirements for serial production.

LGA Certificate no.: 572(year)060 – to be found at www.jual.dk.