

# Installation & Operation Manual



## E-COMPACT 15 Outdoor Pellet Boiler

1. Introduction	2
2. Warnings and Guarantee / Warranty Information	3
2.1 Safety Instructions	3
2.2 Operating Warnings	4
2.3 Guarantee / Warranty Information	4
2.3.1 Limitations	5
2.3.2 Exclusions	5
3. Pre-Installation Considerations	6
3.1 Pellets	6
3.2 Considerations for Installation	7
3.3 Operating Area	8
3.4 Connection to the Flue	9
3.5 Operating Problems Caused by Draft Defects in the Flue	10
3.6 Plumbing Connections	11
4. Installation and Assembly	12
4.1 Unpacking	12
4.2 Preparing the Base	13
4.3 Electrical Connections	14
4.4 Control Panel Schematic	15
4.5 Water Connections	16
5. Control System	18
5.1 Error Codes	20
6. Boiler Operation and Maintenance	21
7. Technical Data	25
8. Boiler Handling	27
9. Service Log	28

## 1. INTRODUCTION

Dear Customer,

We wish to thank you for choosing this ECOMPACT pellet boiler product from Wood Energy Solutions (WES).

**In order to get the best performance from your appliance we recommend that you read this booklet carefully before lighting the appliance for the first time.**





While thanking you again, may we remind you that the appliance **MUST NOT** be used by children, and that they must always be kept at a safe distance from it!

### Revisions to the publication

In order to improve the product, to keep this publication up to date the manufacturer reserves the right to make modifications without any advance notice. Any reproduction, even in part, of this manual without the consent of the manufacturer is prohibited.

### Care of the manual and how to consult it

- Take good care of this manual and keep it in a place which can easily and quickly be reached.
- If this manual should be lost or destroyed, or if it is in poor condition, ask for a copy from your retailer or directly from the manufacturer, providing product identification data.
- Information which is essential or that requires special attention is shown in **bold text**.
- Italic text is used to call your attention to other paragraphs in the manual or for any additional clarifications.

	<p><b>ATTENTION</b></p> <p>This warning sign indicates that the message to which it refers should be carefully read and understood, because failure to comply with what these notices say can cause serious damage to the boiler and put the user's safety at risk.</p>
	<p><b>INFORMATION</b></p> <p>This symbol is used to highlight information which is important for proper boiler operation. Failure to comply with these provisions will compromise use of the boiler and its operation will not be satisfactory.</p>
	<p><b>OPERATING SEQUENCES:</b></p> <p>Indicates a sequence of buttons to be pushed to access menus or to make adjustments.</p>
	<p><b>MANUAL</b></p> <p>Indicates that you should carefully read this manual or the related instructions.</p>

## 2. WARNINGS AND GUARANTEE /WARRANTY INFORMATION

### 2.1. SAFETY INSTRUCTIONS



- Installation of the boiler, making the electrical connections, checking its operation, and maintenance are all tasks which should be carried out by qualified and authorised personnel.
- Install the boiler in accordance with the regulations in force in your local area, region and country.
- For the correct use of the appliance and to prevent accidents, the instructions given in this booklet must always be followed.
- Use, adjustment and programming must be carried out by adults. Errors or incorrect settings may cause hazardous conditions and/or poor operation.
- Before beginning any operation, the user, or whoever is preparing to operate on the appliance, must have read and understood the entire contents of this instruction booklet.
- All responsibility for improper use is taken entirely by the user and such use relieves WES of any civil or criminal responsibility.
- Any kind of tampering or unauthorised substitution of non-original spare parts can be hazardous for the safety of the operator and relieves WES of any civil or criminal responsibility.
- Most of the surfaces of the appliance are extremely hot (the boiler door, the handle, smoke discharge pipes, etc.). Avoid coming into contact with these parts, without adequate protective clothing or suitable implements such as gloves with thermal protection or implements which keep the hands cool.
- Carefully explain this hazard to elderly people, disabled people and particularly to all children, keeping them away from the appliance while it is running.
- **Under no circumstances should the appliance be run with the door open.**
- Do not touch the appliance with wet hands, in view of the fact that it is an electrical appliance.
- Before carrying out any cleaning or maintenance operation, make sure in advance that the appliance is isolated from the mains electricity supply, by removing the mains isolator fuse.
- The appliance must be connected to an electrical system which is equipped with an earth conductor, as laid down in directives 73/23 EEC and 93/98 EEC.
- The fuse must be of adequate rated capacity for the stated electrical power of the appliance.
- Incorrect installation or faulty maintenance (not conforming to the requirements set out in this booklet) can cause harm to people, animals or property. In such cases WES is absolved from any civil or criminal responsibility.



Adhesives sealants and paints used in the manufacture of the product are cured and present no known hazards when used in the manner for which they were intended. The appliance contains no asbestos.

## 2.2. OPERATING WARNINGS



- Shut the appliance down in the event of a breakdown or bad running.
- Pellets must not be fed manually into the burner.
- Accumulated un-burnt pellets in the burner after repeated failed ignitions must be removed before re-lighting.
- Do not wash the inside of the heat exchanger with water.
- Do not wash the appliance with water. The water could get inside the unit and damage the electrical insulation and cause electric shocks.
- Do not put any fuel, other than wood pellets, in the hopper .
- Install the appliance in a location which is suitable for fire-fighting, and equipped with all services such as air and electricity supply and provision for discharging combustion gases.
- If there is a fire in the flue pipe, extinguish the appliance, disconnect it from the power supply and never open the door. Then contact the competent authorities.
- If the appliance is in storage, it should be in a place that is free of damp, and it should not be exposed to extremes of temperature.
- It is inadvisable to base the appliance directly on a floor (if located indoors), and if the floor is made of flammable material, it must be suitably insulated.
- Do not light the appliance with flammable materials if the ignition system breaks down.

## INFORMATION



- In case of any problems, get in touch with your dealer, or a qualified engineer authorised by WES, and if a repair is necessary, insist on the use of original spare parts.
- Use only the fuel recommended by WES (ENplus-A1) may be used with this appliance.
- Periodically check and clean the smoke outlet ducts (connection to the flue pipe).
- Accumulated un-burnt pellets in the burner after repeated failed ignitions must be removed before lighting.
- Always keep the cover of the fuel hopper closed.
- Keep this instruction manual carefully because it must stay with the appliance throughout its working life. If the appliance is sold or transferred to another user, always make sure that the booklet goes with the product.
- If it gets lost, ask WES or your authorised dealer for another copy.

## 2.3. GUARANTEE CONDITIONS

WES offers the following warranties on this appliance :

- Leaks in the heat exchanger – 5 years
- Faulty electrical components (motors, fan, controller) – 2 years
- Pump, Ignition Element – 1 year

from the date of first ignition of the appliance as proved by a valid Commissioning Report which gives the name of the Installer / Commissioning Engineer and the date on which the commissioning took place. The guarantee is conditional on the

Commissioning Report being filled in and returned to the Manufacturer within 10 days, and requires that the product be installed and commissioned by an approved WES installer according to the detailed instructions given in the instruction booklet supplied with the product.

The term 'guarantee' is to be understood to denote the free of charge replacement or repair of **parts recognised to have been defective at the start by reason of manufacturing defects.**

### 2.3.1. Limitations

The above guarantee does not cover parts subject to normal wear such as gaskets, fibre board on doors and any parts which can be removed from the firebox such as burner pot, baffles and ash box. The replacement parts will be guaranteed for the remainder of the guarantee period starting from the date of commissioning of the product.

### 2.3.2. Exclusions

The warranty excludes all ancillary products associated with the system ( e.g. flue pipes, external circulation pumps, bulk hoppers and augers, plumbing and electrical system.). The warranty does not cover Third Party damage to the product or damage caused by the plumbing (an example would be an inappropriately sized expansion vessel) or electrical system. Warranty does not cover issues arising from pellets that do not conform to Enplus-A1

Recommendations advised to the Customer to be carried out during commissioning must be completed and advised to your local Dealer in order to validate the warranty.

The requirements for the flue installation, particularly in relation to draught, is the responsibility of the system owner. Compliance with Local Building Regulations must be adhered to.

The warranty does not cover misuse of the product or sabotage.

**Any consequential loss or damage caused by the failure of a component on this product is not covered.**

WES refuses to accept any responsibility for any damage which may be caused, directly or indirectly, by persons, animals or things in consequence of the failure to observe all the prescriptions laid down in the instruction booklet, especially those concerning warnings on the subject of installation, use and maintenance of the appliance.

Damage caused by transport and/or handling is excluded from the guarantee.

The guarantee will be invalidated in the event of damage caused by tampering with the appliance, atmospheric agents, natural disasters, electrical discharges, fire, defects in the electrical system, and caused by lack of, or incorrect, maintenance in terms of the manufacturer's instructions.

### CLAIMS UNDER THE GUARANTEE



**The request for action under the guarantee must be addressed to the Dealer/Retailer, who will forward the claim to WES's technical assistance service. WES DECLARES THAT THE APPLIANCE WHICH YOU HAVE PURCHASED COMPLIES WITH EEC DIRECTIVE 2004/108 EC and 2006/95/EC and SUCCESSIVE AMENDMENTS**



**WES refuses to accept any responsibility in the event that the appliance or any other accessory has been improperly used or modified without authorisation. For all replacement of parts, only original WES spare parts must be used.**

### 3. Pre-Installation Considerations

#### 3.1. Pellets

Wood pellets are manufactured by hot-extruding compressed sawdust which is produced during the working of natural dried wood. The compactness of the material comes from the lignin which is contained in the wood itself, and allows the production of pellets without the use of glues or binders.

The market offers different types of pellet with characteristics which vary depending on what mixture of woods is used. The diameter varies between 6 mm and 8 mm, with a standard length in the range 5 mm to 30 mm. Good quality pellets have a density which varies between 600 kg/m<sup>3</sup> and 750 kg/m<sup>3</sup>, with a moisture content which varies from 5% to 8% by weight.

Besides being an ecological fuel (exploiting timber residues to the maximum and achieving cleaner combustion than is possible with fossil fuels), pellets also have technical advantages. While good-quality timber has a calorific power of 4.4 kW/kg (with 15% moisture, therefore after about 18 months' seasoning), the equivalent figure for pellets is 4,9 kW/kg.

To ensure good combustion, the pellets must be stored in an area that is free of humidity and protected from dirt. The pellets are usually supplied in 10 kg. bags, so storing them is very convenient.

Good quality pellets ensure good combustion, thus lowering the emission of harmful agents into the atmosphere.



**The poorer the quality of the fuel, the more frequently will intervention be necessary for cleaning the internal parts, such as the grate and the combustion chamber.**

The main certification of quality for pellets in the European market are Enplus-A1 these ensure respect of:

- ✓ Calorific power: 4.9 kW/kg
- ✓ Water content: max 10% of weight
- ✓ Percentage of ashes: max 0,5% of weight
- ✓ Diameter: 6mm
- ✓ Length: max 30mm
- ✓ Contents: 100% untreated wood, with no added bonding substances (bark percentage 5% max)
- ✓ Packaging: in sacks made from ecologically compatible or biologically decomposing material.



Certificate No. UK301



WES recommends using certified fuel in its appliances to ENplus-A1. The use of fuel of inferior quality or not conforming to the specification given above compromises the running of your appliance and can therefore lead to the termination of the guarantee and of the manufacturer's responsibility for the product.

WES domestic pellet appliances run exclusively on pellets with a diameter of 6 mm.

### 3.2. CONSIDERATIONS FOR INSTALLATION

#### IMPORTANT!

**Installation and assembly of the appliance must be carried out by qualified personnel.**

The appliance must be installed in a suitable position to allow the normal operations of opening and ordinary maintenance.

The site must be:

- capable of providing the environmental conditions for operation
- equipped with power supply 230V 50 Hz (EN73-23)
- capable of taking an adequate system for smoke discharge
- provided with external ventilation (if located indoors)
- provided with an earth connection complying with CEI 64-8

**The appliance must be connected to a flue pipe or an internal or external vertical duct conforming to current standards UNI7129 - 7131 9615.**

**The boiler must be positioned in such a way that the power isolation fuse is accessible.**

#### IMPORTANT!

**The boiler must be connected to a flue pipe or a vertical duct which can discharge the fumes at the highest point of the building.**



The fumes are however derived from the combustion of wood products, and if they come into contact with or close to walls, they can cause smoke staining. Also take care because the fumes are very hot and almost invisible, and can cause burns on contact.



### 3.3 OPERATING AREA

For proper functioning, the appliance should be positioned in a location where it is able to take in the air necessary for combustion of the pellets (about 40 m<sup>3</sup>/h must be available), as laid down in the standard governing the installation and in accordance with local national standards. All louvres on the external casing of the boiler must be un-obstructed at all times as these allow air for combustion and for cooling to enter the appliance enclosure. Heavy snowfall can also obstruct the air in-take louvres and cause the appliance to not burn clean. Smoke emanating from the flue is a symptom of this. Snow must be cleared from around the appliance at the earliest opportunity.



**Where the appliance is to be installed indoors it is not permissible to install the appliance where another heating appliance is installed (fireplace, stove etc.) which does not have its own independent air intake. Locating the appliance in a room with an explosive atmosphere, e.g workshop or tool shed, is prohibited. The floor of the room where the appliance is to be installed must be strong enough to take its weight.**

If the walls are not flammable, position the appliance with a clearance to the rear of at least 45 cm.

For flammable walls, keep a minimum distance of 45 cm at the rear, 30 cm on the sides and 150 cm at the front.



**If the flooring is made of wood, provide a floor protection surface in compliance with current national standards.**



#### Service Clearances

The minimum service clearances around the appliance are as follows :

Rear – 600mm

Side (lid hinge side) – 600mm

Side (lid open side) – 900mm

Front – 1200mm

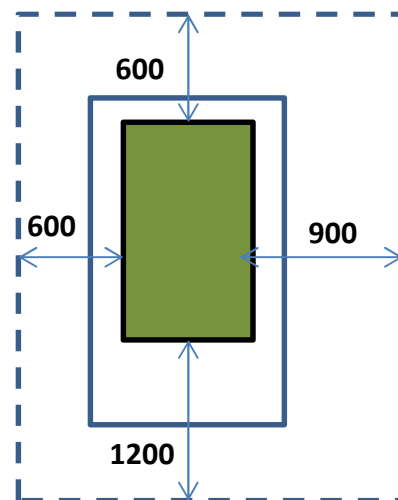

### 3.4. CONNECTION OF THE FLUE

WES recommend that the Therminox range of stainless steel insulated flue pipe is used with this product. A full range of straight, offset, elbow and 'T' elements is available to overcome any obstruction which the flue should avoid. The proper draught conditions in the flue is critical for the efficient working of wood pellet boilers. The flue can exit the boiler house/garage through the roof or through the wall by using a bend on the flue. The combustion chamber works in negative pressure. The smoke duct for the discharge of fumes will also be under negative when connected to an efficient flue pipe as directed.



All sections of the flue must be capable of inspection and removable to enable periodic internal cleaning.

Position the appliance bearing in mind all the instructions and considerations above.



**IMPORTANT!**

All 90 degree changes of direction in the flue pipe must be either removable or capable of inspection

**THE FLUE PIPE RUN MUST NOT INCLUDE MORE THAN 2-3 METRES OF HORIZONTAL PIPE MUST AND NOT MORE THAN THREE 90° ELBOWS (INCLUDING 'T's). IT IS ALSO ADVISABLE NOT TO EXCEED 8 METRES IN LENGTH WITH THE PIPE Ø 80 mm**

WES recommends the use of 80mm Therminox flue for use with this appliance.

### 3.5. OPERATING PROBLEMS CAUSED BY DRAUGHT DEFECTS IN THE FLUE

Of all the weather and geographical conditions which affect the operation of a flue pipe (rain, fog, snow, altitude a.s.l., exposure to sunlight, direction of facing), the **wind** is unquestionably the most decisive. In fact, along with thermal depression caused by the difference in temperature inside and outside of the chimney, there is another type of depression or over-pressure: dynamic pressure caused by the wind. An updraft always increases depression and hence draught. A crosswind increases depression provided the cowl has been installed properly. A downdraft always decreases depression, at times inverting it.

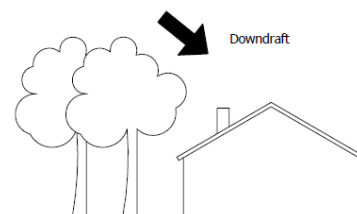

E.g. Downdraft at 45° of 8m/sec. Overpressure of 17 Pa

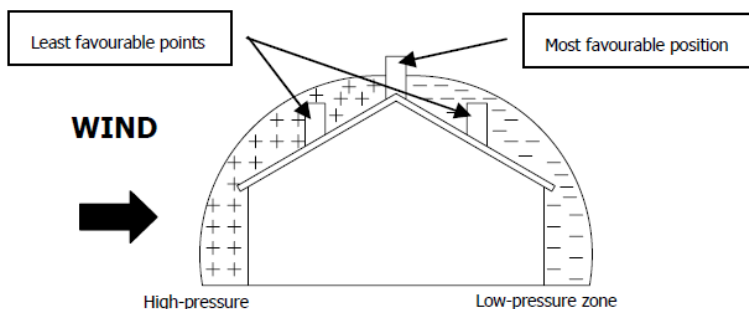

E.g. Crosswind 2 : 8m/sec. Depression of 30Pa

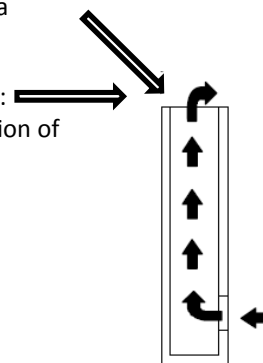

Besides the direction and force of the wind, the position of the flue and the cowl with respect to the roof of the building and the surrounding landscape is important.

The wind also influences the operation of the chimney indirectly by creating high-pressure and low-pressure zones, not only outside the building but inside as well. In rooms directly exposed to the wind **(2)**, an indoor high-pressure area can be created which can augment the draught in boilers, stoves and fireplaces, but it can be counteracted by the external high pressure if the cowl is situated on the side exposed to the wind **(1)**. On the other hand, in the rooms on the opposite side from the direction of the wind **(3)**, a dynamic depression can be created which competes with the natural thermal depression developed by the chimney, but this can be compensated for (sometimes) by locating the flue on the opposite side from the direction of the wind **(4)**.

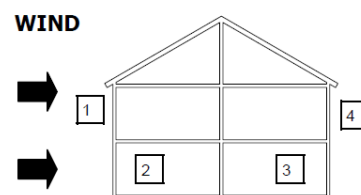

**1-2 = High-pressure zones**  
**3-4 = Low-pressure zones**



**IMPORTANT!**

The operation of the pellet boiler is noticeably sensitive to the conformation and position of the flue which is adopted.

Hazardous conditions can only be overcome by suitable setting-up of the boiler carried out by qualified WES personnel.

### 3.6 PLUMBING CONNECTION

**IMPORTANT!**

The connection of the boiler to the plumbing system must be carried out **ONLY** by specialized personnel who are capable of carrying out installation properly, in compliance with current standards in the country of installation.

If installation of the boiler will involve interaction with another, pre-existing system complete with heating equipment (gas boiler, methane boiler, fuel oil boiler, etc.), it is even more advisable to call in qualified personnel, who subsequently will be responsible for conformity of the system with current applicable law.

**WES will not be held responsible for damage to persons or things in the event of failed or incorrect operation if the aforementioned warnings are not complied with.**

For connection of the plumbing system to the appliance, the user should refer to chapter 4, INSTALLATION AND ASSEMBLY; specifically, paragraph 4.5, CONNECTION TO PLUMBING SYSTEM

## 4. INSTALLATION AND ASSEMBLY

### 4.1. UNPACKING

The ECOMPACT 15 Pellet Boiler will come packaged on a single pallet. The flue will be packaged separately.



The materials which make up the packaging are 100% recyclable. Their storage or recycling are therefore the responsibility of the final user, in compliance with local regulations. Do not store the boiler without its packaging. Remove the nylon strapping, cardboard packaging and bubble wrap and recycle in the appropriate manner.

When unpacking the boiler use the checklist below to ensure that all the required components to complete the kit have been supplied. In the unlikely event of an omission you must notify the manufacturer within 48 hrs of delivery. The Manufacturer reserves the right to charge for items deemed lost after 48hrs.

#### Unpacking checklist

Item	Location	Received YES/NO
Baffle Set – 3 Pieces	Combustion Chamber	
Burner Pot	Combustion Chamber	
User Manual Pack *	Combustion Chamber	
Boiler flue support brackets x 2	Hopper	
Stainless flue support brackets x 2	Hopper	
Single – twin wall flue adaptor	Hopper	
Flue 90° elbow	Hopper	
Rain cap	Hopper	
Flue straight lengths 1m x 2	Supplied in separate packaging	

\* The User Manual Pack includes a User Manual, Quick Step User Instructions, Commissioning Report, keys for lockable doors and a heat proof glove.

## 4.2. PREPARING THE BASE

Careful planning at an early stage will greatly help the installation process and make sure that all the required clearances are adhered to for servicing and that any potential issues with the routing of the flue can be resolved.

The ECOMPACT pellet boiler should be positioned on a concrete plinth at least 50mm high and should project a min. 100mm beyond the sides and the rear of the appliance and at least 600mm to the front. The plinth must be capable of supporting the weight of the appliance when full with fuel and the plumbing system has been filled with water.

Use the template below for constructing the plinth and for positioning the flow and return pipework and electrical supply.



Refer to service and access clearances around the appliance on Page 8

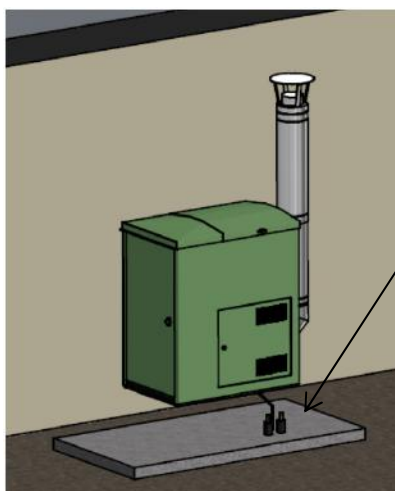
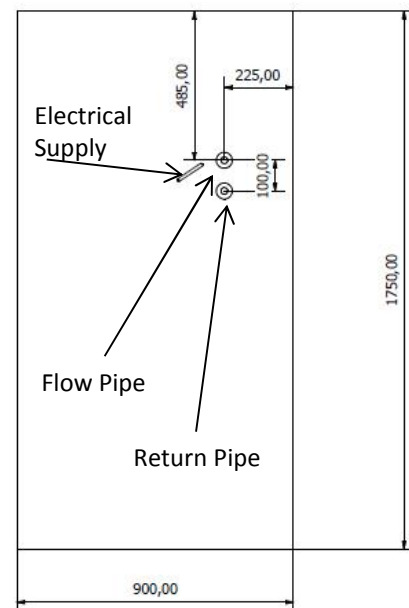
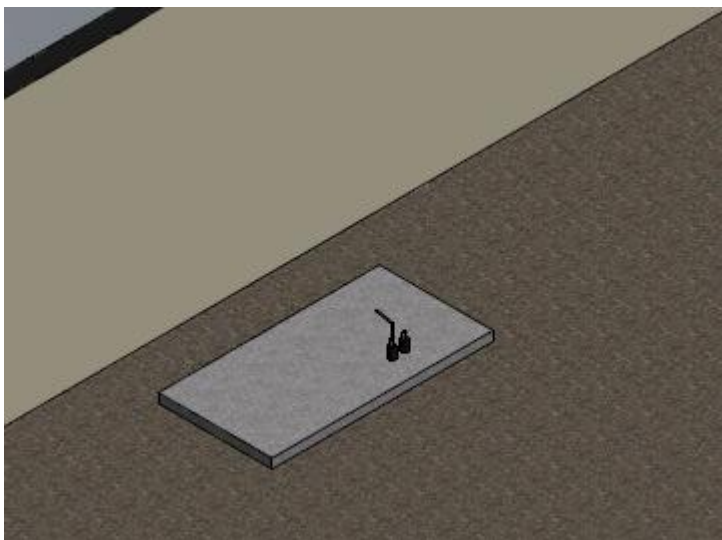

Carefully position boiler over pipes.

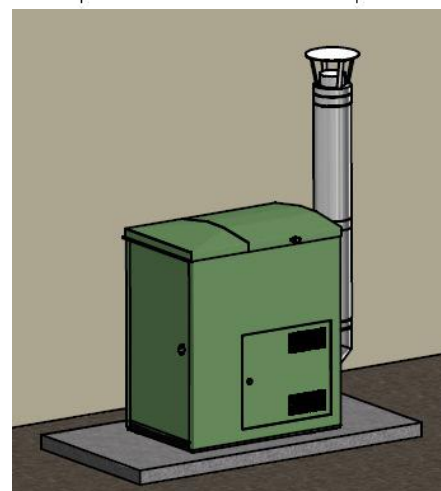

### 4.3 ELECTRICAL CONNECTIONS



Electrical installations should only be carried out by suitably qualified and certified electricians. If in doubt on any issue relating to the electrical connections on the appliance contact WES Technical Support or your Local Dealer for guidance before carrying out any connections.

The ECOMPACT boiler must be supplied with a 230V 50 Hz electrical supply via a two pole isolation switch rated for Overvoltage Category III and protected with a 6A circuit breaker. Also, the unit shall have a 30mA RCD installed into the mains supply. It is recommended that a power isolation switch is located adjacent to the boiler to isolate the power during servicing and maintenance but also out of the reach of children and to prevent accidental turning off of the mains power.



Room thermostats shall be supplied/controlled by safety extra low voltage.

Brown - Time Clock Control Live  
Black – Permanent Live  
Blue – Neutral  
Green / Yellow - Earth



Only authorized WES personnel may open the control panel on the boiler. Any interference with the wiring in the control panel will invalidate the warranty. The boiler and complete plumbing system must be adequately earthed and bonded in accordance with local Building Regulations and Bye- Laws.

## 4.4 BOILER CONTROL PANEL SCHEMATIC

### Electrical Connections

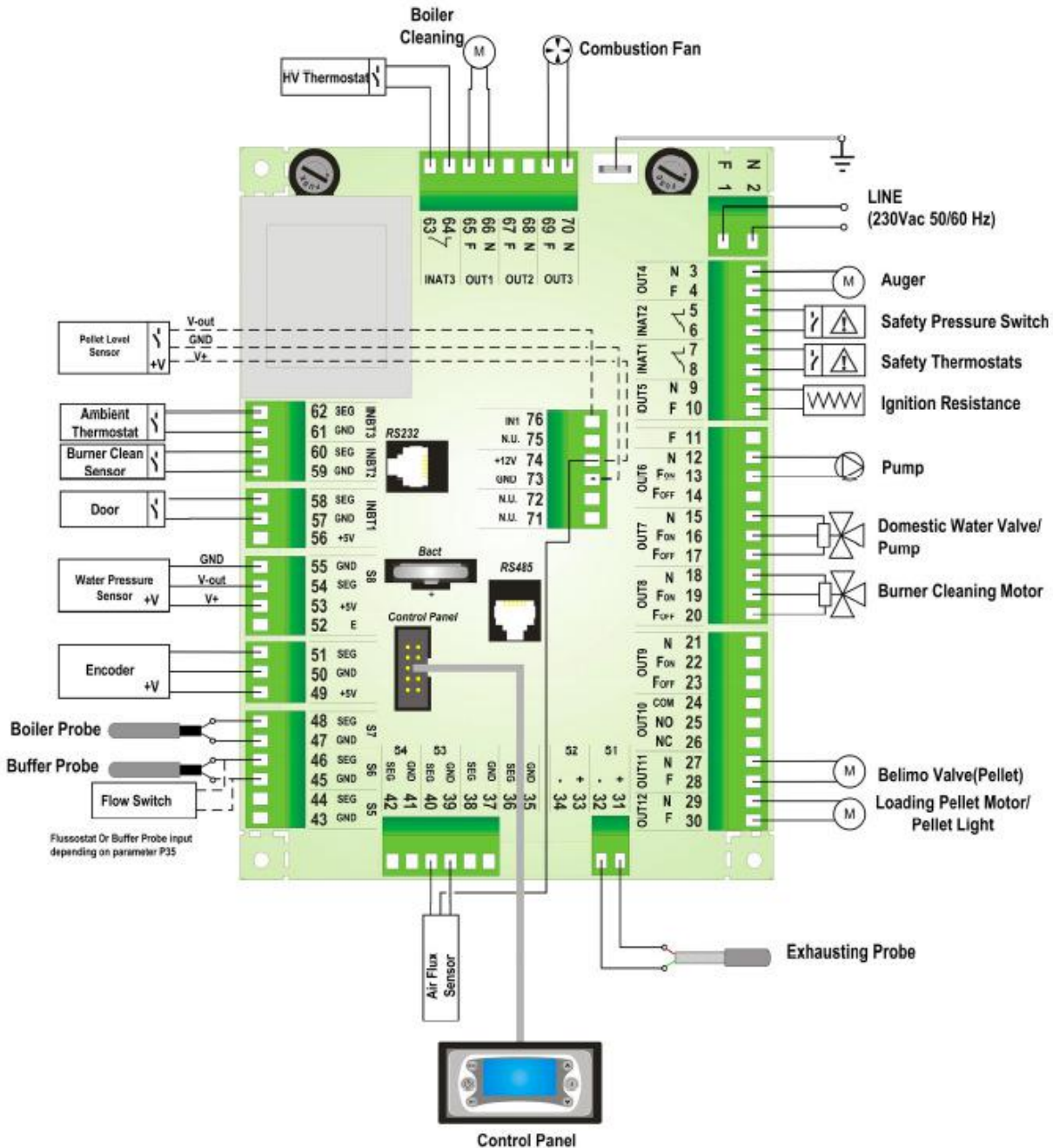

Only authorised WES personnel may open the control board. Any tampering with the PCB will immediately invalidate the warranty.



## 4.5 WATER CONNECTIONS

The diagram below indicates the plumbing connections at the rear of the boiler. The return connection is factory fitted with a 25/6 Standard pump.

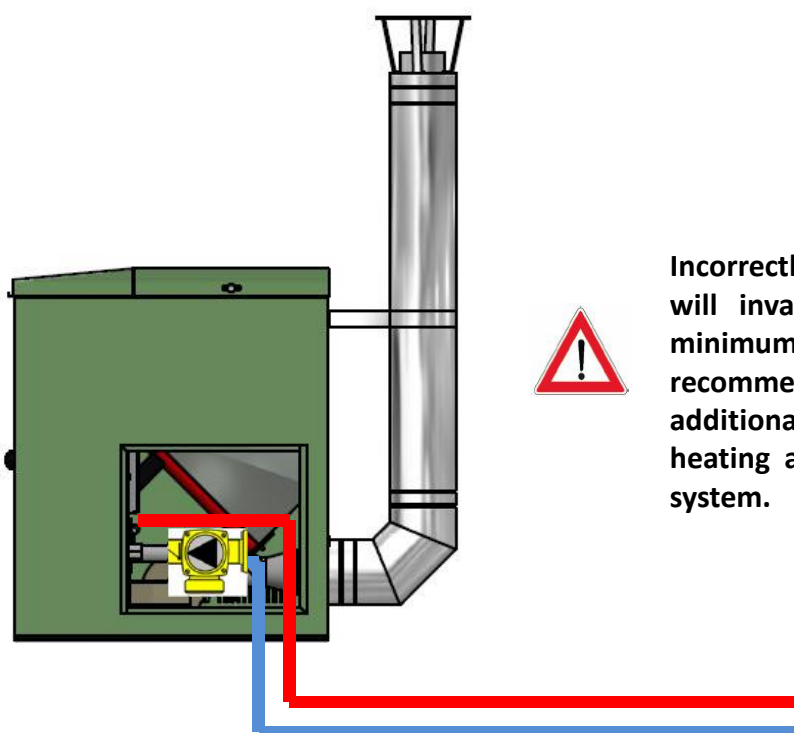

**Incorrectly sized expansion vessel will invalidate the warranty. A minimum 18 litre vessels is recommended for the boiler plus additional expansion for the heating and domestic hot water system.**

The boiler can be plumbed into either an open vented system (the maximum static head of water permissible is 90 ft. (27.44 meters) or a sealed system. If plumbed into a sealed system an appropriately sized expansion vessel should be used and installed as per manufacturers instructions. The expansion vessel should be sized based on the water capacity in the boiler and the water in the entire heating system.

The pump is on the return pipework just before the boiler. It is recommended that a by-pass pipe between the flow and return is used with a valve to regulate the temperature of the water returning to the boiler. Also, the system designer should ensure that there is adequate provision in the system for heat dissipation from the boiler during the shut-down / extinguishing phase..An automatic air vent and pressure relief valve must be fitted to the flow pipework immediately outside the boiler. The pressure relief valve should be piped to a drain to prevent injury to the User or Service Technicians if it is activated. All unused connections should be sealed with blanking plugs.

A non-return valve should be fitted to prevent back-siphonage

Once the plumbing has been completed the system should be fully flushed to clear any debris which may have become lodged in the pipework. The system should generally be filled from the lowest point on the system to force any air to the highest point where it can be vented. The flow pipe on the boiler is fitted with a manual air vent for venting air from the boiler. The system must then be filled and the pump can be run continuously for a few hours to completely de-aerate the system. Hold the ESC button on the controller for 3 seconds to activate the pump. Repeat the procedure to turn it off. Only when the system has been fully vented can the boiler be commissioned.

The installation and the design of the central heating system must be in accordance with BS EN 14336:2004: Heating Systems in Buildings. Installation and commissioning of water based heating systems. BS EN 12828: 2003; Heating Systems in Buildings. Design of water based heating systems. BS EN 12831: 2003; Heating Systems in Buildings. Method for calculation of the design heat load.



Always ensure that all connections are making a watertight seal.

- 3/4" Flow
- Water pressure sensor
- Pre-fitted Pump on Return
- Drain



**Always check that fittings are tight and sealed when filling the boiler**

- 1/2" BSP Connections for PRV and Optional Extras. Black Tappings not being used.

- Manual Air Vent on Flow



## 5. CONTROL SYSTEM

### ***CONTROL PANEL***

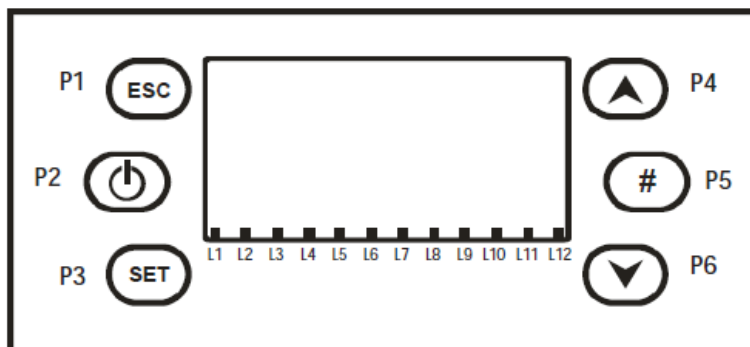

FUNCTION	DESCRIPTION	<i>Button</i>
<b>ON/OFF</b>	Function: <b>Ignition, Extinguishing</b> by pushing the button for 3 seconds until the acoustic signal.	<b>P2</b>
<b>UNBLOCK</b>	Function: <b>unlock</b> . When the system is in <b>Block</b> by pushing the button for 3 seconds until the acoustic signal.	
<b>MODIFY VALUES INTO MENU</b>	In modify mode change menus and submenus values.	<b>P4</b>
<b>RUN ON MENU AND SUBMENU</b>	In Menu run on submenu and menu.	<b>P6</b>
<b>ESC</b>	Function Exit managed pushing the button if in a menu or a submenu. Out of menu "Pump Test"	<b>P1</b>
<b>MENU</b>	Function: Enter in menu or in a submenu.	<b>P3</b>
<b>MODIFY</b>	Enter in modify mode into a menu.	
<b>SET</b>	Save data in a menu.	
<b>ENABLE CHRONO PROGRAMMING</b>	In Chrono menu -> Chrono Program : enables the selected program.	<b>P5</b>
<b>KEYBOARD LOCK</b>	To lock keyboard keys keep this button pressed for 3 seconds. To unlock repeat the same procedure.	

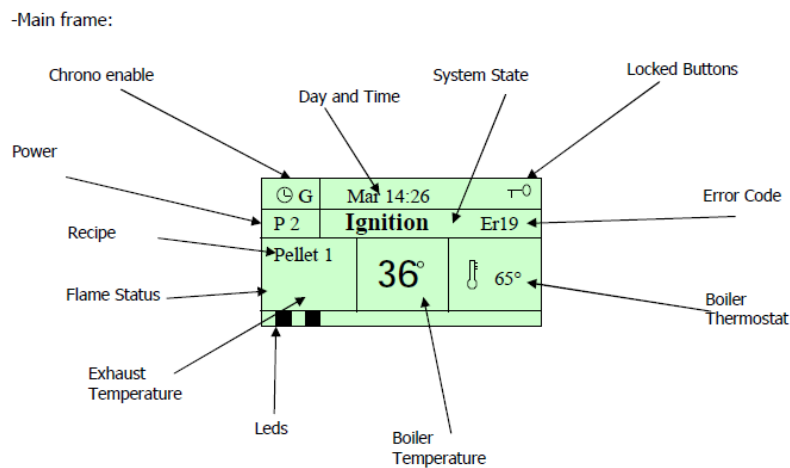

<b>ERRORS</b>	
<b>DESCRIPTION</b>	<b>DISPLAY</b>
Error activation Safety thermostat High voltage	<b>Er01</b>
Error activation <i>Pressure switch</i> (Only with the Exhaust fan ON)	<b>Er14</b>
Accidental Extinguishing for low Exhaust Temperature	<b>Er03</b>
Water over-temperature	<b>Er04</b>
Exhaust over-temperature	<b>Er05</b>
Encoder Error Error can occurs for lack of Encoder Signal	<b>Er07*</b>
Encoder Error. Error can occurs in case of adjustment problems of rounds number	<b>Er08*</b>
Water pressure low	<b>Er09</b>
Water pressure high	<b>Er10</b>
Real Time Clock error	<b>Er11</b>
Ignition Failed	<b>Er12</b>
Lack of voltage	<b>Er15</b>
Air Flow Regulator Error	<b>Er17</b>
Extinguishing for Lack of Pellet	<b>Er18</b>
Burner Cleaning System Fault	<b>Er33</b>

\* Only for product with Encoder

## 5.1 ERROR CODES

In the unlikely event that the appliance fails to start or shuts down unexpectedly, then the Error code show on the display will give an indication as to the potential cause of the problem. Some of the errors can be cleared by the house holder and they are :

**Er01** - Water Safety Thermostat – Press the reset button A and then hold button B for three seconds to clear the error from the controller.

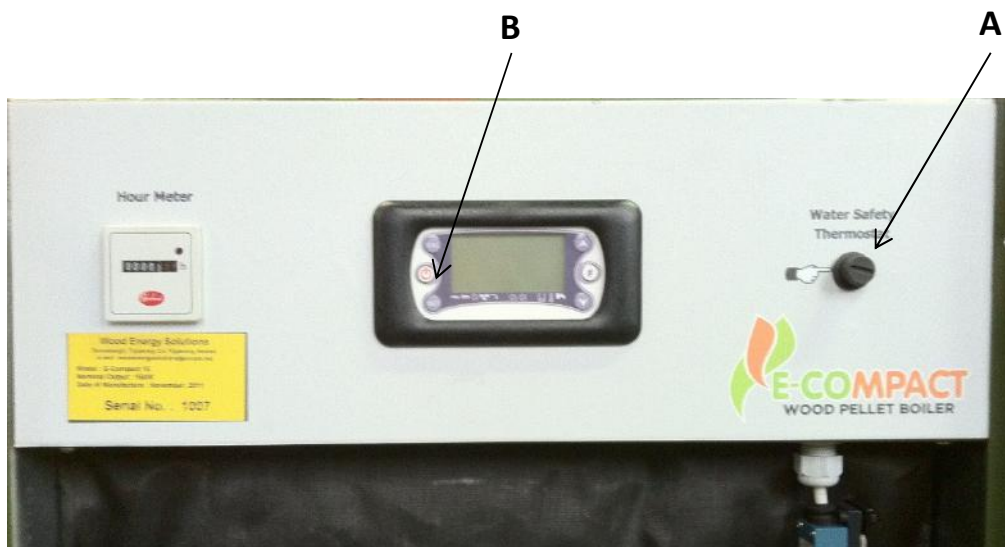

**Er03** - Accidental Extinguishing for Low Exhaust Temperature – Empty any un-burnt pellets from the burner pot and hold button B for three seconds.

**Er04** - Water over temperature – Hold button B for three seconds. If the problem persists contact you service agent.

**Er12** - Failed Ignition– Empty any un-burnt pellets from the burner pot and hold button B for three seconds.

**Er15** - Loss of Voltage– Usually occurs after a power-cut. Empty any un-burnt pellet from the burner pot and hold button B for three seconds.

**Er18** – Lack of Pellet – When the pellets reach the pellet sensor in the hopper the system extinguishes to prevent having to re-prime the auger.



Other errors can appear on the display but these may only be cleared by service personnel.

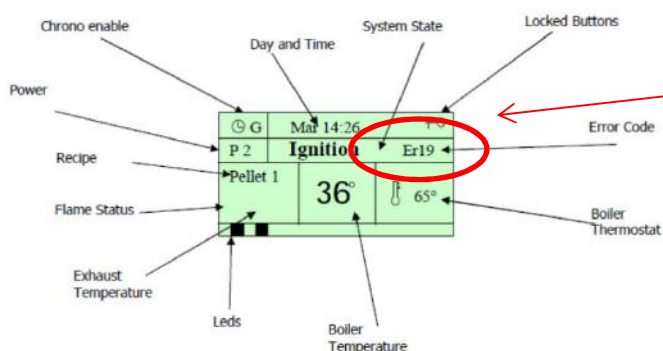

Error codes must be notified to the service personnel in order to diagnose the problem.

## 6 BOILER OPERATION & MAINTAINANCE

The ECOMPACT 15 has been developed to ensure that the User is able to carry out the most basic functions in a safe and convenient manner. Once the installation has been successfully carried out the User interaction is quiet simple from a regular inspection on the combustion chamber to remove ash to filling the hopper with pellets.

### Turning ON and OFF the boiler

- It is recommended that your boiler is controller by an external time clock. The time programs should be set to the times that heat is required at different periods throughout the day. You should also make allowance for the ignition time of the appliance, i.e. the time it takes from when the time clock signals the boiler to start until the flame has fully developed in the appliance (usually approx. 10-20 minutes).
- When choosing your programs on your time clock it is recommended that you program the clock for long runs instead of short runs. This gives the boiler time to settle and match the heat demand of the property. It is also when the boiler is most efficient.
- If the boiler is not being controlled by a time clock then it can be turned on and off locally at the display on the boiler control panel. Hold the ON/OFF button for 3 seconds to start the boiler. Hold the ON/OFF button for 3 seconds to turn off the boiler.

### Emptying the Ash Pan

- The boiler contains two areas where ash needs to be removed at regular intervals.
- The primary ash pan is located in the main combustion chamber. The frequency of emptying the ash pan is determined by the length of time the boiler has been running and under what load conditions. Once the ash in the ash pan has reached the top then it should be emptied. A daily check during the first few days of operation will give an indication as to when it needs to be emptied.



**Always make sure that before you open the main combustion chamber door that the boiler has been switched off as has been allowed to cool down sufficiently so as not to cause injury.**

**Always empty ash into a metal container as ash which may appear cool could be hot in the centre.**

**Never use plastic brushes or dust pans to clean ash from the boiler.**

**Always use heat resistant gloves when handling the ash pan or cleaning the boiler.**



When the combustion chamber door is opened, even with the boiler in the OFF position, the combustion fan will run at full power



Always allow boiler to cool down before opening the combustion chamber door.

Ash pan full. Carefully remove ash empty ash into a metal container.



Remove the slider plate under the grate before removing the ash pan.

Carefully remove the ash pan and dispose of the ash into a metal container.



Remove the burner pot.

Remove any ash from the pot using the tool provided.



Always replace the slider plate once the ash pan has been emptied.



- The secondary ash pan is located under the main combustion chamber. This needs to be emptied less frequently.



Secondary ash pan area.



Unscrew locking nuts.



Carefully remove secondary ash pan and dispose of ash into a metal container.

### Emptying the Ash Pan

- The boiler contains two areas where ash needs to be removed at regular intervals.
- The primary ash pan is located in the main combustion chamber. The frequency of emptying the ash pan is determined by the length of time the boiler has been running and under what load conditions. Once the ash in the ash pan has reached the top then it should be emptied. A daily check during the first few days of operation will give an indication as to when it needs to be emptied.



### Filling With Fuel

- The boiler will indicate when the level of pellets reaches a low level. The system will shut down and will wait for the hopper to be refilled.
- Open the pellet hopper lid and carefully pour approved pellets into the hopper.
- Never fill the hopper above the guard mesh across the opening of the hopper.



**Never allow any foreign material to enter the hopper. This will lead to the malfunction of the auger system and could cause damage to the appliance and invalidate your warranty.**



**Always close the lid to the hopper once it has been filled with pellets.**

**Never leave the hopper lid open for prolonged periods as rain or moisture can affect the pellet.**

**Always supervise children when the hopper lid is open in case foreign material is placed into the hopper or children climb into the hopper.**

## 7. TECHNICAL DATA

Technical Data		ECOMPACT 15
Nominal Output	kW	4.8 – 16.1
Nominal Fuel Input	Kg/hr	1 – 3.5
Efficiency Nominal Output (EN 303-5)	%	90.7
Smoke Temperature at Nominal Power	°C	130-150
Smoke Temperature at Reduced Power	°C	70-90
Min. Required Draft	Pa	10
Exhaust Gas Mass Flow	g/s	6 - 11
CO2 at Reduced and Nominal Power	%	6 - 12
Water Operating Temperature Range	°C	50 - 85
Maximum Operating Pressure	Bar/kPa	3 / 269 kPa
Recommended Operating Pressure	bar	1.5
Water Flow Connection	inch	22mm
Water Return Connection	inch	22mm
Boiler Drain	inch	1/2"
Boiler Safety Thermostat Setting	°C	105
Boiler Class	Class	Class 3
Boiler Electrical Power Requirement		230V 50Hz
Max. Electrical Consumption	Watts	< 500
Avg Electrical Consumption in Normal Running	Watts	164
Line Voltage Fuse Protection	Amp	6 Amp
PCB Fuse Protection	Amp	1 Amp
Width	mm	600
Height	mm	1100
Length (Excluding Flue)	mm	920
Fuel Hopper Capacity	kg	110
Boiler Flue Diameter (I.D)	mm	80
Boiler Dry Weight	kg	160
Water Content	litres	18

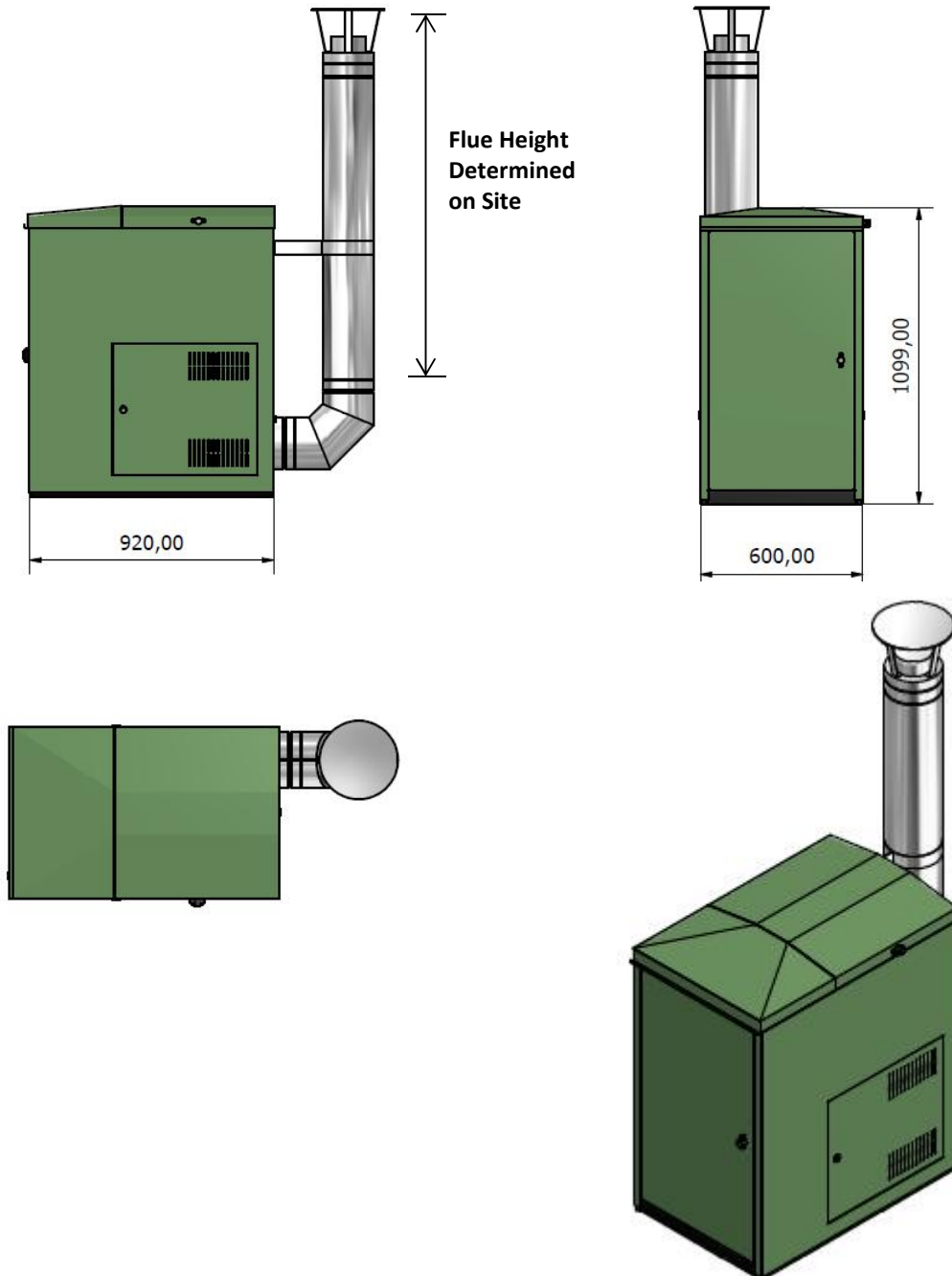

## 8. BOILER HANDLING

.One of the key feature of the E-Compact 15 is it's size and ability to be transported to and located in confined spaces. Care should also be exercised when manoeuvring the appliance into position. The illustration below indicates the weight distribution of the appliance.



Total Dry Weight – 160kg

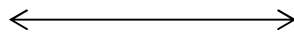

2/3<sup>rd</sup> dry weight in this area



Always protect the appliance when transporting on trolleys or hand carts.



Only persons who have been trained in manual handling techniques should attempt to move the appliance. Incorrect lifting techniques can cause serious injury.

<u>Date</u>	<u>Service Provided</u>	<u>Service Engineer</u>
<u>Date</u>	<u>Service Provided</u>	<u>Service Engineer</u>
<u>Date</u>	<u>Service Provided</u>	<u>Service Engineer</u>
<u>Date</u>	<u>Service Provided</u>	<u>Service Engineer</u>
<u>Date</u>	<u>Service Provided</u>	<u>Service Engineer</u>
<u>Date</u>	<u>Service Provided</u>	<u>Service Engineer</u>

## **Wood Energy Solutions**

Donaskeigh, Tipperary, Co. Tipperary, Ireland

[info@woodenergysolutions.ie](mailto:info@woodenergysolutions.ie)

[www.woodenergysolutions.ie](http://www.woodenergysolutions.ie)

